

ISSN 1816-9554

SURVEYING AND BUILT ENVIRONMENT

Surveying & Built Environment

Vol. 16 Issue 2 ■ December 2005

Vol. 16 Issue 2 ■ December 2005

 THE HONG KONG INSTITUTE OF
SURVEYORS
香港測量師學會
www.hkis.org.hk

Surveying & Built Environment

THE HONG KONG INSTITUTE OF SURVEYORS

Information

No part of this Journal may be reproduced without the permission of the Institute. Contents of the Journal do not necessarily reflect the views or opinion of the Hong Kong Institute of Surveyors and no liability is accepted in relation thereto.

ISSN 1816-9554

Copyright © 2005

All rights reserved and reproduction in any form prohibited unless permitted in writing by the Hong Kong Institute of Surveyors.

Circulation: 6,800 copies to all members free of charge

To subscribe or unsubscribe, please email: linda@hkis.org.hk



THE HONG KONG INSTITUTE OF
SURVEYORS

801 Jardine House, 1 Connaught Place,
Central, Hong Kong SAR,
香港測量師學會 People's Republic of China

Telephone 电话 : (852) 2526 3679 Fax 传真 : (852) 2868 4612

Website 网址 www.hkis.org.hk Email 电邮 editor@hkis.org.hk

Editorial Board

■ Honorary Editor

Francis Leung
Honorary Secretary
The Hong Kong Institute of Surveyors
Hong Kong SAR, People's Republic of China

■ Chairman and Editor-in-Chief

Professor Kwong-wing Chau
Department of Real Estate and Construction
The University of Hong Kong
Hong Kong SAR, People's Republic of China

■ Editor Vol 16 Issue 2

Professor Eddie Hui
Department of Building and Real Estate
The Hong Kong Polytechnic University
Hong Kong SAR, People's Republic of China

■ Members

Professor Seaton Baxter OBE
Emeritus Professor
The Scott Sutherland School
The Robert Gordon University
United Kingdom

Professor Terry Boyd
School of Construction Management & Property
The Queensland University of Technology
Australia

Dr Man-wai Chan
Estates Office
Hong Kong Baptist University
Hong Kong SAR, People's Republic of China

Professor Yong-qi Chen
Department of Land Surveying and Geo-Informatics
The Hong Kong Polytechnic University
Hong Kong SAR, People's Republic of China

Dr Franco Cheung
Department of Building and Construction
The City University of Hong Kong
Hong Kong SAR, People's Republic of China

Dr Sai-on Cheung
Department of Building and Construction
The City University of Hong Kong
Hong Kong SAR, People's Republic of China

Professor Zhen-ming Ge
Department of Construction Management and
Real Estate
The Tongji University
People's Republic of China

Professor Cliff Hardcastle
School of the Built and Natural Environment
The Glasgow Caledonian University
United Kingdom

Professor Bo-sen He
School of Management
The University of Tianjin
People's Republic of China

Professor Patric H Hendershott
School of Business
The University of Aberdeen
United Kingdom

Dr Daniel Ho
Department of Real Estate and Construction
The University of Hong Kong
Hong Kong SAR, People's Republic of China

Professor Malcolm Hollis
Department of Construction Management and
Engineering
University of Reading
United Kingdom

Professor Per-Erik Josephson
Department of Building Economics and
Management/COMESA
The Chalmers University of Technology
Sweden

Professor Masahiko Kunishima
Department of Civil Engineering
The University of Tokyo
Japan

Professor Andrew YT Leung
Department of Building and Construction
The City University of Hong Kong
Hong Kong SAR, People's Republic of China

Dr Anita Liu
Department of Real Estate and Construction
The University of Hong Kong
Hong Kong SAR, People's Republic of China

Professor Hong-yu Liu
Department of Construction Management
The Tsinghua University
People's Republic of China

Mr KK Lo
Department of Building and Real Estate
The Hong Kong Polytechnic University
Hong Kong SAR, People's Republic of China

Mr KF Man
Department of Building and Real Estate
The Hong Kong Polytechnic University
Hong Kong SAR, People's Republic of China

Dr Esmond Mak
Department of Land Surveying and
Geo-Informatics
The Hong Kong Polytechnic University
Hong Kong SAR, People's Republic of China

Professor Graeme Newell
School of Construction, Property and Planning
The University of Western Sydney
Australia

Professor Stephen O Ogunlana
School of Civil Engineering
The Asian Institute of Technology
Thailand

Professor Li-yin Shen
Department of Building and Real Estate
The Hong Kong Polytechnic University
Hong Kong SAR, People's Republic of China

Professor Martin Skitmore
School of Construction Management & Property
The Queensland University of Technology
Australia

Dr Conrad Tang
Department of Land Surveying and
Geo-Informatics
The Hong Kong Polytechnic University
Hong Kong SAR, People's Republic of China

■ Secretary

Linda Chan
The Hong Kong Institute of Surveyors
801 Jardine House
1 Connaught Place
Central, Hong Kong
Tel (852) 2526 3679
Fax (852) 2868 4612
Email: linda@hkis.org.hk

Journal Objectives

Surveying and Built Environment is an international peer reviewed journal that aims to develop, elucidate, and explore the knowledge of surveying and the built environment; to keep practitioners and researchers informed on current issues and best practices, as well as serving as a platform for the exchange of ideas, knowledge, and opinions among surveyors and related disciplines.

Surveying and Built Environment publishes original contributions in English on all aspects of surveying and surveying related disciplines. Original articles are considered for publication on the condition that they have not been published, accepted or submitted for publication elsewhere. The Editor reserves the right to edit manuscripts to fit articles within the space available and to ensure conciseness, clarity, and stylistic consistency. All articles submitted for publication are subject to a double-blind review procedure.

■ Topics

All branches of surveying, built environment, and commercial management including, but not limited to, the following areas:

- Agency and brokerage;
- Asset valuation;
- Bidding and forecasting;
- Building control;
- Building economics;
- Building performance;
- Building renovation and maintenance;
- Business valuation;
- Cadastral survey;
- Commercial management;
- Concurrent engineering;
- Construction law: claims and dispute resolution;
- Construction management and economics;
- Construction technology;
- Corporate real estate;
- Education and training;
- Engineering and hydrographic survey;
- Facilities management and intelligent building;
- Geodetic Survey;

- Geographical Information System (GIS);
- Health and safety;
- Heritage conservation;
- Housing markets and policy;
- Information technology;
- International construction;
- Land law;
- Lean construction;
- Mortgage;
- Organization, scheduling and planning;
- Photogrammetry and remote sensing;
- Portfolio management;
- Procurement and contracting;
- Professional ethics;
- Project financing;
- Project management;
- Property development;
- Property finance;
- Property investment;
- Property management;
- Property market dynamics;
- Property valuation;
- Space planning;
- Sustainability;
- Securitized real estate;
- Town planning and land use;
- Urban economics;
- Value engineering.

For Submission Guidelines or enquiries, please contact the Secretary of the **Surveying and Built Environment** Editorial Board, Linda Chan, at 801 Jardine House, 1 Connaught Place, Central, Hong Kong; e-mail: linda@hkis.org.hk, telephone (852) 2526 3679 or fax (852) 2868 4612. For information on the Hong Kong Institute of Surveyors, please visit: www.hkis.org.hk.

From the Editor

It is time for publishing the first issue of Surveying and Built Environment (formerly the Hong Kong Surveyors) for 2005. This December issue presents four reviewed papers. They highlight a range of surveying and built environment areas: namely, use of energy; real estate market; construction project organizations and kinematic airborne laser survey.

The first article by WP Wong, AMM Liu and RF Fellows examines the use of electrical energy in University buildings and the impact of both technical and behavioural factors on energy consumption. Their findings suggest that high temperature and relative humidity during summer can be mitigated by improved control systems and increased awareness among users. Second, LHT Chui and KW Chau study the lead-lag relationships between real estate prices, real estate investments and economic growth. Their results reveal that there is no relationship between GDP and real estate investment.

The third article by BC Lam and AMM Liu investigates the extent of bureaucracy and red tape in public and private construction project organizations based on different organizational culture and structures. Fourth, O Al-Bayari, B Saleh and M Barbarella conduct a quality assessment of kinematic airborne laser survey. They also propose some recommendations to be implemented on the helicopter to improve reception of the GPA signal.

Finally, I would like to thank all members of the editorial board for their support and assistance. This is the last issue for the year 2005. May I take this opportunity to wishing all HKIS fellow members Merry Christmas and a Happy New Year.

Professor Eddie Chi Man HUI
Editor Vol 16 Issue 2

Acknowledgement

The **Surveying and Built Environment** Editorial Board would like to thank the following academics for their contribution to the article review process:

Dr Man-wai CHAN

Professor Yong-qi CHEN

Dr Sai-on CHEUNG

Dr Richard FELLOWS

Professor Zhenming GE

Dr Daniel HO

Dr Paul HO

Dr Mei-yung LEUNG

Dr Anita LIU

(Surname in alphabetical order)



Submission Guidelines

ELECTRONIC SUBMISSION

Full paper submission should consist of a file in Microsoft Word format attached to an e-mail message.

FORMAT OF FULL PAPER

Language

English

Content

Full Paper should include title of paper, author details, ABSTRACT, KEYWORDS and REFERENCES.

Paper length

Full paper should not be more than 20 pages, including all text, graphs, tables, diagrams, maps, pictures, illustrations, and appendices.

Paper size

set paper size to A4. The lines of text (except the text under ABSTRACT) should be indented left and right 3cm from the paper margin.

Text font

Times New Roman

Abbreviations

No full stop is needed for titles, names, acronyms, and measurement units: eg, Mr, Dr, PRC, UK, HKSAR, Jan, Feb, Mar, 4m, 5ft.

Abstract

drop 2 line spaces and type **ABSTRACT** in bold, full caps, 12 point size, and centred. On the next line, type the content of the Abstract in 10-point size, indent 3cm on both margins, left and right justified.

Abstract should be a single paragraph outlining the aims, scope, and conclusion of the paper. It should be no more than 300 words in length.

Keywords

drop 2 line spaces and type **KEYWORDS** in bold, full caps, 12-point size, and left justified. Type the keywords in the next line and indent 3cm on both margins, left and right justified. Suggest approximately 5-10 keywords spaced by commas.

Main Text

drop 2 line spaces before typing each of the above topics. The text should be single spaced, single column, indented 3cm on both margins, left and right justified, and 12-point size. Paragraphs should not have any indentations. Any abbreviations used should be defined.

Section headings are in bold and full caps. There should be no blank lines between the heading and the first line of text. Separate paragraphs in each Section with one blank line. There should be two blank lines before each Section.

Equations should be centred, with a spaced line above and below. Equation font size should be the same as that of the text. Use only those mathematical symbols supported by Microsoft Word.

All graphs, tables, diagrams, maps, pictures, and other illustrations should be in black and white. They should be labeled and embedded in the text as close as possible to where they are first cited.

References and table headings should appear above the table. Tables are to be centred on the

page. Leave one blank line before the table heading and one blank line after the table.

Illustrations are to be centred, with the reference and caption printed below the figure. Footnotes should appear at the bottom of the page where they are cited, numbered and in 10 point size.

References

drop 2 line spaces and type **REFERENCES** in bold. All references should be in 12-point size, left and right justified, indented 3cm on both margins for the first line and 3cm on the left margin for subsequent lines. List all bibliographical references in alphabetical order by the last name of the first author at the end of the paper the following format:

Journals

last name and initials of author(s), (year of publication), paper title, journal title (*italics*), journal volume: issue, page numbers, for example:

Stewart R (2001), the Spatial Data Infrastructure: Concept, Prototype Development and Future Direction, *GIS - Today and Tomorrow*, 28:2, 155-177.

Books

last name and initials of author(s), (year of publication), book title (*italics*), edition (if any), publisher, for example:

Blachut CD (1979), *Urban Surveying and Mapping*, Springer-Verlag, New York.

Chapters in books

last name and initials of author(s), (year of publication), paper/chapter title, book title (*italics*), - last name and initials of book editor(s) (eds.), name of publisher, for example:

Wofford, L E (1999), *Ethical Choice in Real Estate: Selected Perspectives from Economics, Psychology, and Sociology*, Ethics in Real Estate, Roulac, S (ed.), Kluwer Academic Publishers, Massachusetts, 39-70.

The reference should be cited in the article by typing the last names of the authors (without any title) and year (in brackets), e.g. Steward (2001) and Fellows and Liu (1999), or Lai, et. al. (2005) in case of more than 3 authors. References to the same author(s) in the same year should be differentiated by using 2005a, and 2005b etc.

COPYRIGHT TRANSFER

Submission of an article for publication implies the transfer of the copyright from the authors to the Hong Kong Institute of Surveyors upon acceptance, and all authors are required to sign a Transfer of Copyright Form. The final decision of acceptance rests with the Editorial board. Authors are responsible for all statements made in their articles.

FINANCIAL DISCLOSURE AND DISCLAIMERS

Any affiliation with or involvement in any organization or entity with a direct financial interest in the subject matter or materials discussed in the manuscript should be disclosed in an attachment. Any financial or material support should be identified in the manuscript.

FOR ENQUIRIES

Please email linda@hkis.org.hk or call the Secretary of the Surveying and Built Environment Editorial Board on (852) 2526 3679. Full papers are to be sent by email to the Editor at: linda@hkis.org.hk.



THE HONG KONG INSTITUTE OF
SURVEYORS

香港測量師學會

Surveying and Built Environment

Volume 16 Issue 2 December 2005 ISSN 1816-9554

CONTENTS

Journal Objectives

Articles

WP Wong, AMM Liu and RF Fellows

Use of Electrical Energy in University Buildings: A Case Study in Hong Kong

7

LHT Chui and KW Chau

An Empirical Study of the Relationship between Economic Growth, Real Estate Prices and Real Estate Investments in Hong Kong

19

BC Lam and AMM Liu

Bureauracy and Red Tape in Public and Private Construction Project

Organizations

33

Omar Al-Bayari, Bassam Saleh and Maurizio Barbarella

Quality Assessment Of Kinematic Airborne Laser Survey

43

Submission Guidelines

53

Use of Electrical Energy in University Buildings: A Case Study in Hong Kong

WP Wong¹, AMM Liu² and RF Fellows³

ABSTRACT

This paper addresses the issue of electrical energy consumption in a small sample of buildings on a university campus in Hong Kong. Data are used to produce deterministic time series models and so aid analysis of the climatic effects on energy consumption. Semi-structured interviews are employed to supplement the base data. Both technical factors impacting on energy consumption and behavioural considerations are addressed. Conclusions demonstrate the impact of functions housed in the buildings and their intensity of occupation on energy consumption, and that the increased consumption to combat high temperatures and relative humidity during the summer can be mitigated by improved control systems and increased awareness of users to induce less energy consuming behaviour.

KEYWORDS

electrical energy, HVAC, life cycle costing, university buildings

INTRODUCTION

Predicting buildings' life cycle costs is an enduring problem. Many difficulties of forecasting remain, although much has been documented concerning techniques, problems of data collection and reliability. Attention to the energy embodied in buildings, used in construction (and disposal) processes, and buildings' consumptions of energy in use gained momentum following the major 'oil shocks' of 1973 / 4 and 1979. Life cycle models have been developed to aid energy efficiency in designing buildings although most early models were quite inaccurate. Fortunately, since the 'early days', attention to environmental

protection, to 'green' programmes, and to 'sustainability', has encouraged the development of more comprehensive, detailed and accurate life cycle models.

Given the size, and importance, of construction projects, the infrequent use of life cycle models for project feasibility analyses raises concerns. Graves, Sheath, Rowe and Sykes (1998) found that neither clients (including consultants) nor constructors carry out life cycle analyses for many projects. Further, Nicolini, Tomkins, Holti, Oldman and Smalley (2000) assert that, "whole life-cycle costing was little used because

- no strong client requirement to whole life costing and no marked long-term interest in the cost of ownership;
- insufficient availability of reliable data on life-cycle costs;
- whole-life targets were rarely monitored and

^{1, 2} Department of Real Estate and Construction

The University of Hong Kong, Pokfulam Road, Hong Kong

³ Department of Real Estate and Construction

The University of Hong Kong, Pokfulam Road, Hong Kong
fellows@hkucc.hku.hk and School of the Built and Natural
Environment, Glasgow Caledonian University, Scotland richard.
fellows@gcal.ac.uk

- there was no well-established standard methodology.”

Life cycle modelling comprises technique(s) for evaluation of assets of potential long-life (choice of life period – physical, economic, etc. – may be problematic). The desirability of such an evaluation to secure effective and efficient investments is clear; techniques are well-known but the reasons for their lack of use in the ‘IT-age’ must, it seems, lie in issues concerning data and forecasting, together with aspects of ‘market forces’ generating opportunistic, short-term, self-interest operating criteria under which the dominant consideration is market price / profitability.

Today, sustainability is a topic of recognised, major importance, and, even, of popular debate. Provision and use of buildings globally is, arguably, the highest resource consumption category of human activities. Many definitions of sustainability, although praiseworthy in intent, are little more than ‘mission statements’ in indicating how sustainability may be achieved. The World Commission on Environment and Development (1987) (the Brundtland Report) defined sustainable development as, “development that meets the needs of the present without compromising the ability of future generations to meet their own needs”. However, to achieve sustainability, a strict, meaningful definition is required – such as **‘the activity is a net non consumer of resources’**.

The function of strict definition is to promote debate of what sustainability is and how it may be effected. If we regard sustainability as only **reducing** resource consumption and / or **reducing** pollution and waste, then such a relative approach, even in a context of ‘continuous improvement’, is likely to yield totally inadequate results! That is a significant danger of ‘benchmarking’ as applied to energy / resource management – the problem of complacency through being ‘best in class’ – even if coupled with continuous improvement. Cole (1999) classifies ‘green’ performance of buildings as

being in relative / comparative terms (potentially employing benchmarking) but ‘sustainability’ performance measures are expressed in absolute terms (via measures of energy embodiments, consumption, etc.). That is a valuable and very helpful differentiation.

University buildings are used increasingly intensively and so, coupled with cuts in funding, the search for more efficient operation of the buildings, whilst maintaining their effectiveness, is imperative; use reliability and flexibility are additional concerns. Anecdotal evidence indicates that a typical academic building in a Hong Kong university consumes electricity at a 2004 annual cost of HK\$ 2.5 – 3.5 million (US\$ 0.31 – 0.44 million). From 1999 to 2003, consumption of electricity in Hong Kong increased by almost 20%, mostly through commercial sector usage, far outstripping the increase in population.

This paper identifies the main factors affecting the pattern of electrical energy consumption, the nature(s) of the effects, managerial issues involved, and develops (deterministic) time series forecasting models for the university buildings studied. Given that most of the world's buildings exist as stock (rather than new supply), the results indicate potential energy savings more generally.

PROPERTY MANAGEMENT USING LIFE CYCLE MODELS

In order to use life cycle models for property management, it is essential to be familiar with the techniques involved, including the assumptions and issues in their operation. The assumption that costs reasonably represent embodied resources is important; that relationship depends on the market and the value structures of the participants. Strictly, the relationship is founded upon the assumptions of perfect markets and consequent Pareto optimality. In practice, those conditions are never satisfied and so, the further the market structure is from the perfect market construct, the less accurately costs reflect resource embodiments. Hence, it is preferable to measure

consumption in suitable units of resources (e.g. energy) rather than in financial terms.

The data problems in life cycle modelling concern life expectancies of materials and components, maintenance requirements and intervals, etc. Usually, the problems are caused by the lack of monitoring and feedback (which has been widespread in the construction and property industry). The issues are compounded by technological changes and by alterations in the requirements for buildings due to changes in tastes and in uses. Such changes can have major consequences on the actual life period of a building which, then, may be very different from that assumed initially.

Such 'objective' data problems are compounded by human factors. When resources and energy were plentiful, and tended to be cheap, designers were concerned with capital costs alone (if they were very concerned with costs at all). For speculative developers, occupation costs fall on others and so, are considered relevant only to the extent that such costs impact on sale price and on time required to effect the sale.

Costs of occupation and associated operation of buildings are highly dependent on the way occupants behave - especially over actions / inactions which impact on energy requirements - as well as cleaning and maintenance.

Clearly, life cycle planning etc. (use of life cycle models to support decisions) is not restricted in use to the initial and design phases of projects. It may play a vital, informing role throughout the life of the project, and may be highly material in determining the time for ending the life of the project. Throughout the life of a building, the approach may be used constantly for deciding service provision (cleaning etc.), maintenance, refurbishment, and energy consumption measures.

ENERGY IN BUILDINGS

Energy in buildings may be classified into

'embodied' and 'consumed'. Embodied energy is, primarily, a matter of design and concerns the energy required to produce the building. Further aspects concern the refurbishment / adaptations of the building and the energy required to dispose of the building at the end of its life, minus energy recovered through re-use of components. Energy consumed relates to the in-use life of the building regarding maintenance and methods of use / occupation. Energy consumed is determined by both the design and function(s) of the building, as well as the behaviour of occupants. Whilst the two primary categories are inexorably related, the focus of this study is on the energy consumed category. The particular focus of this study is the energy consumed during 'normal' working occupation of (university) buildings - one of the four main energy use categories identified by Cole and Kernan (1996).

Scheuer, Keoleian and Reppe (2003) noted that in a 6-storey building on the campus of the University of Michigan, electrical power for the HVAC, lighting and electrical equipment accounts for over 94% of the life cycle energy consumption. Gomez-Amo, Tena, Martinez-Lozano and Utrillas (2004) noted a saving in energy exceeding 20% by changing to high-efficiency (from 'ordinary') fluorescent tubes for lighting. In Hong Kong offices, Lam, Chan, Tsang and Li (2004) noted that (from a survey of 20 office buildings) HVAC consumes 47.5%, lighting 27.4%, electrical equipment 21.8%, and lifts and escalators 3.3% of electricity. Further studies of other building types confirm the primary consumption categories to be HVAC and lighting.

In Hong Kong, seasonal variations in temperature, humidity, and daylight times (and brightness), result in significant variations in consumption of electrical energy in buildings. In Hong Kong, the mild winters mean little space heating is required but the hot and humid summers cause high consumption of electricity for cooling and de-humidifying.

Extensive anecdotal evidence indicates that many

buildings in Hong Kong, and other parts of South-East Asia, are over-cooled - entering them generates discomfort due to low internal temperature. Reasons advanced include mildew precautions and efficiency of plant operation ('flat out'). However, it is interesting that the literal translation of the Chinese term for air conditioning is 'cold air', suggesting that, perceptually, a good quality (well air conditioned) building should have cold air apparent, thereby lending a cultural dimension to the design and operation of air conditioning!

Over the last ten years, consumption of electricity at The University of Hong Kong has increased by 90% whilst the floor area of buildings has increased by 63%. Such a correlation is crude, as changes in uses of spaces, electrical equipment (particularly computers), occupancy periods and intensities, etc. have changed, however, it does suggest that examination of potential for savings are likely to be fruitful. Such potential is demonstrated by the saving of almost 8% in energy consumption for academic year ended 2003 compared with 2002. The measures included setting minimum temperatures for thermostats (23°C), restricting operating times of air conditioning, restricting power to lifts and lighting of circulation space, and modifying lighting in 'over-lit' areas.¹

Universities occupy buildings of particularly diverse functions and designs – from traditional vernacular premises to futuristic, high-tech, intelligent buildings; from quasi-domestic residential buildings to state-of-the-art hospitals and research laboratories. Inevitably, such diversity requires models of energy usage by appropriate typographical categorisation to be developed. Hence, the study reported in this paper examines electricity consumption in a representative sample of 'classroom and office' buildings on the main campus of a University – thereby removing significant variations in local climatic conditions and, pragmatically, minimising the impacts of other variables (such as occupants, occupation patterns, energy supply provisions, and maintenance policy).

DATA AND ANALYSES

Five major academic buildings were selected to be the case studies. Each comprises (mainly) lecture rooms and departmental offices, none was built before 1970, each has centralised air conditioning, and electricity consumption data are available from academic year 1997-98. Basic data were collected for each building – including age, gross floor area (GFA), – see table 1 – usage pattern, and monthly electricity

Table 1 Profiles of buildings

Building	Age (yrs)	GFA (M ²)	Height (M)
C	8	13,941	35.10
K	30	24,434	41.48
L ¹	15	21,640	51.80
M ²	8	14,317	39.25
T ³	7	5,450	49.21

Notes :

- 1 includes some library area and some dining areas
- 2 includes some health care areas
- 3 includes some art gallery and museum areas

¹ During academic year 2002-03, the University consumed just over 91.5 million KwH of electrical energy, the generation of which produced gaseous emissions of 89,722.5 tonnes CO₂, 7.5 tonnes CO, 119 tonnes NOXs, 139.8 tonnes SO₂.

consumed. Face-to-face, semi-structured interviews were held with staff of the University Estates Department to investigate the buildings' envelopes, management and operational activities. Data of monthly mean ambient temperature and relative humidity were obtained from the website of the Hong Kong Observatory.

Initially, scatter plots of the raw data were produced to facilitate 'pattern searches'. Electricity consumption data were plotted per M² GFA, both annually and monthly, to inform subsequent deterministic time series modelling. The modelling used data for academic years 1997/98 – 2001/02; data for year 2002/03 was used to test the model(s). The modelling employed 12-month moving averages (MA) as the trend component for each building; seasonal components were then calculated. Due to the relatively short run of data available, any cyclical components could not be determined and so, remain incorporated in the other components. Multiplicative deterministic time series modelling was employed (see, e.g., Yeomans, 1968).

The Pearson product moment coefficient of correlation was used to test for any relationship between weather conditions (monthly mean ambient temperature; monthly mean relative humidity) and consumption of electricity.

T-tests were used to test the significance of correlation coefficients.

Having produced a model for each building, from deterministic time series analyses and multiple regression methods (via the EView 3.0 statistical package), forecasts were produced from each model to test against the 12 month ex-post data for each building. Goodness of fit was tested by mean absolute percentage errors (MAPE) and root mean squared errors (RMSE).

RESULTS

All five buildings' patterns of electricity consumption gave highly significant ($\alpha = 0.01$) correlations with monthly mean ambient temperature. For monthly mean relative humidity, all buildings showed significant correlations ($\alpha = 0.05$) but only two showed highly significant correlations, see table 2.

Taking the winter (Northern hemisphere: December – February) as the 'base' quarter and using dummy variables for each of the spring (March – May), summer (June – August), and autumn (September – November) quarters, positive and highly significant correlations were found for each building's pattern of electricity consumption.

Table 2 correlations

Building	Correlation: monthly mean ambient temperature & monthly electricity consumption	Correlation: monthly mean relative humidity & monthly electricity consumption
C	0.9179	0.258*
K	0.9202	0.3197
L	0.8387	0.2321*
M	0.9501	0.3275
T	0.7813	0.2725*

$\alpha = 0.01$; except *, where $\alpha = 0.05$

The resulting time series models have good fits with the data for each individual building, with r^2 ranging from 0.72 to 0.80. Further results are shown in table 3.

Table 3 Results of ex-post prediction accuracies

Building	Mean Absolute % Error	Root Mean Square Error (kWh/M ²)
C	6.66	1.61
K	7.26	1.64
L	5.90	1.35
M	7.74	2.40
T	8.60	3.00

The time series models are shown in table 4. All models employ ln Y (natural logarithm of quarterly electricity consumption) as the dependent variable, T is the trend term for each building (T=1 for July 1997 to T=60 for June 2002), S₁ is the seasonal factor for spring, S₂ is the seasonal factor for summer, and S₃ is the seasonal factor for autumn.

Table 4 Deterministic time series models for each building

Building	Model
C	$2.837 - 0.0001441T + 0.2018S_1 + 0.3658S_2 + 0.2348S_3$
K	$2.3914 + 0.001449T + 0.2565S_1 + 0.4355S_2 + 0.2976S_3$
L	$2.7831 - 0.0034T + 0.2007S_1 + 0.3442S_2 + 0.2652S_3$
M	$2.4708 + 0.000521T + 0.2562S_1 + 0.5543S_2 + 0.3276S_3$
T	$3.0542 + 0.003682T + 0.1417S_1 + 0.2992S_2 + 0.1622S_3$

The models and the resultant 12-month ex ante forecasts of each are shown in figures 1-5.

Figure 1 12-month ex-ante forecast for building C

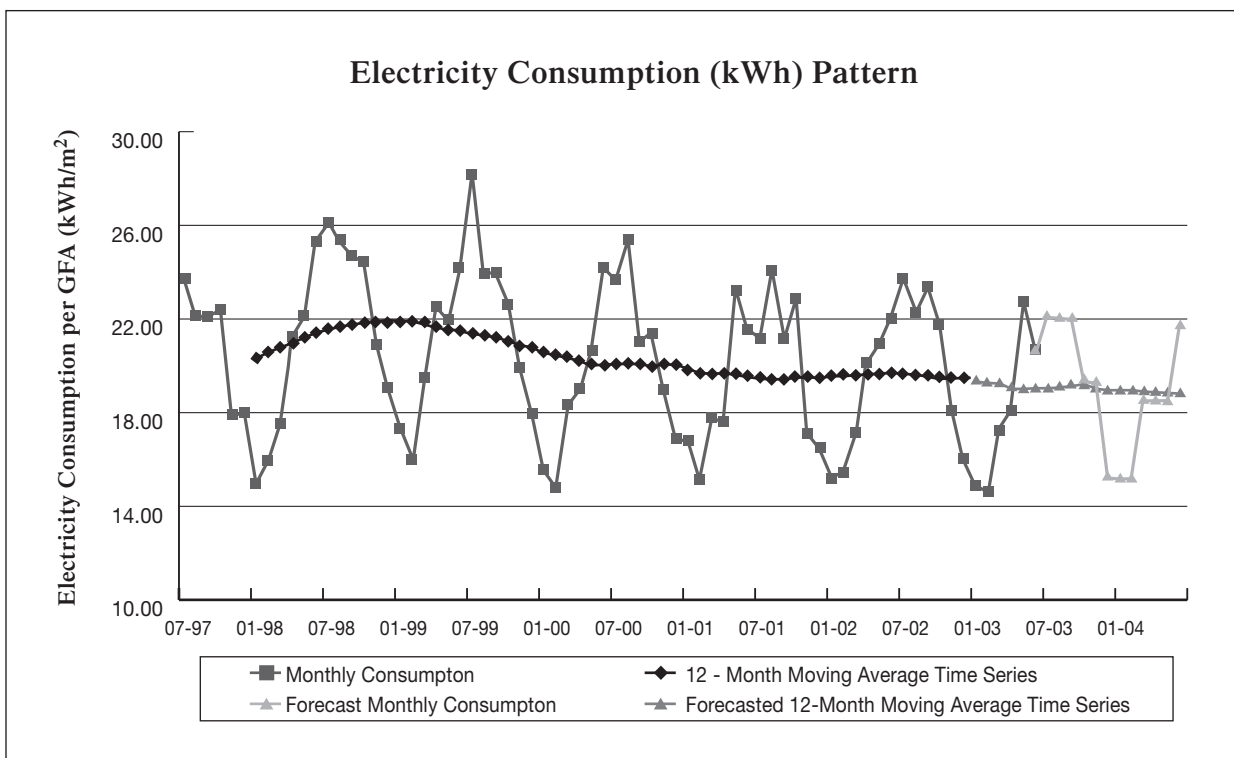

Figure 2 12-month ex-ante forecast for building K

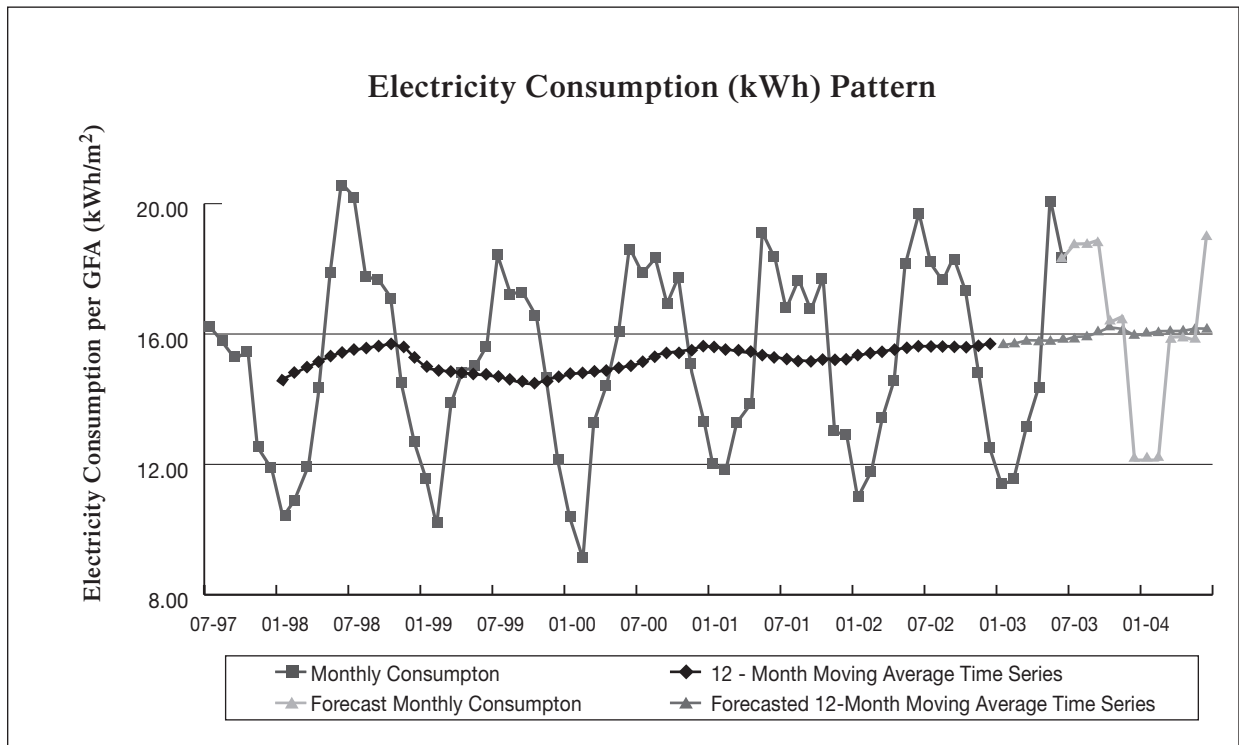

Figure 3 12-month ex-ante forecast for building L

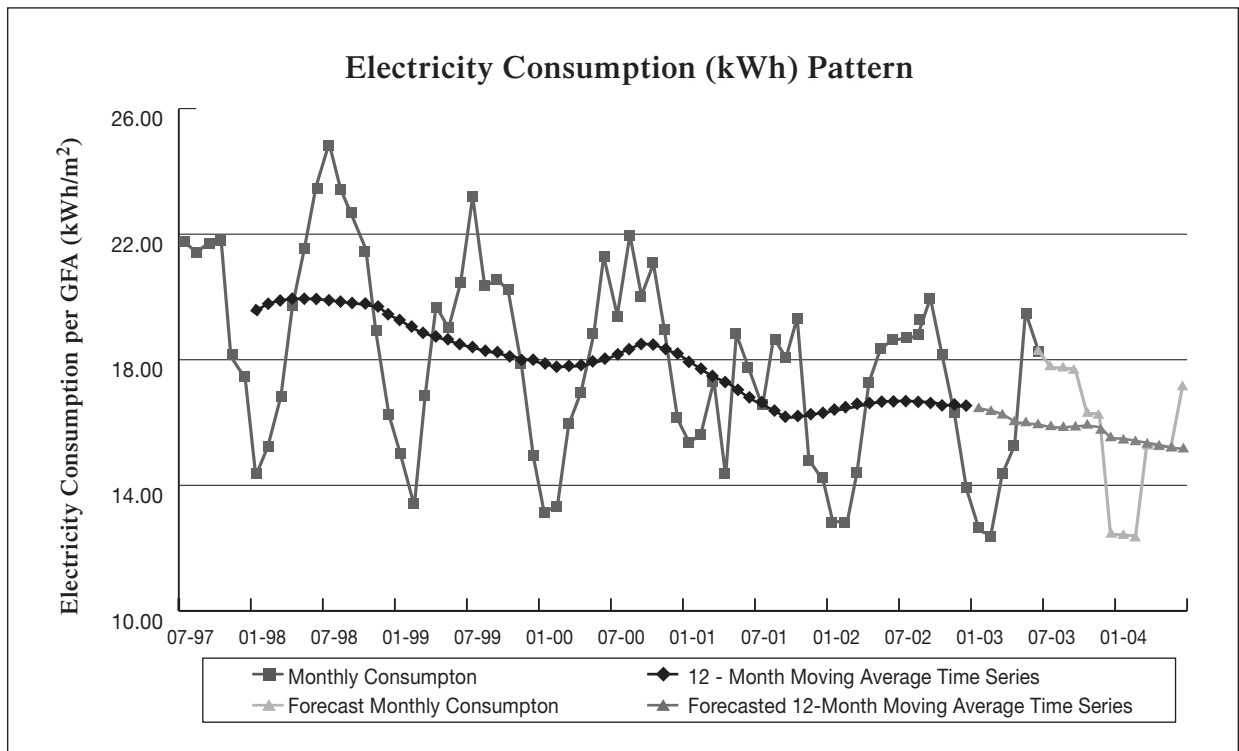

Figure 4 12-month ex-ante forecast for building M

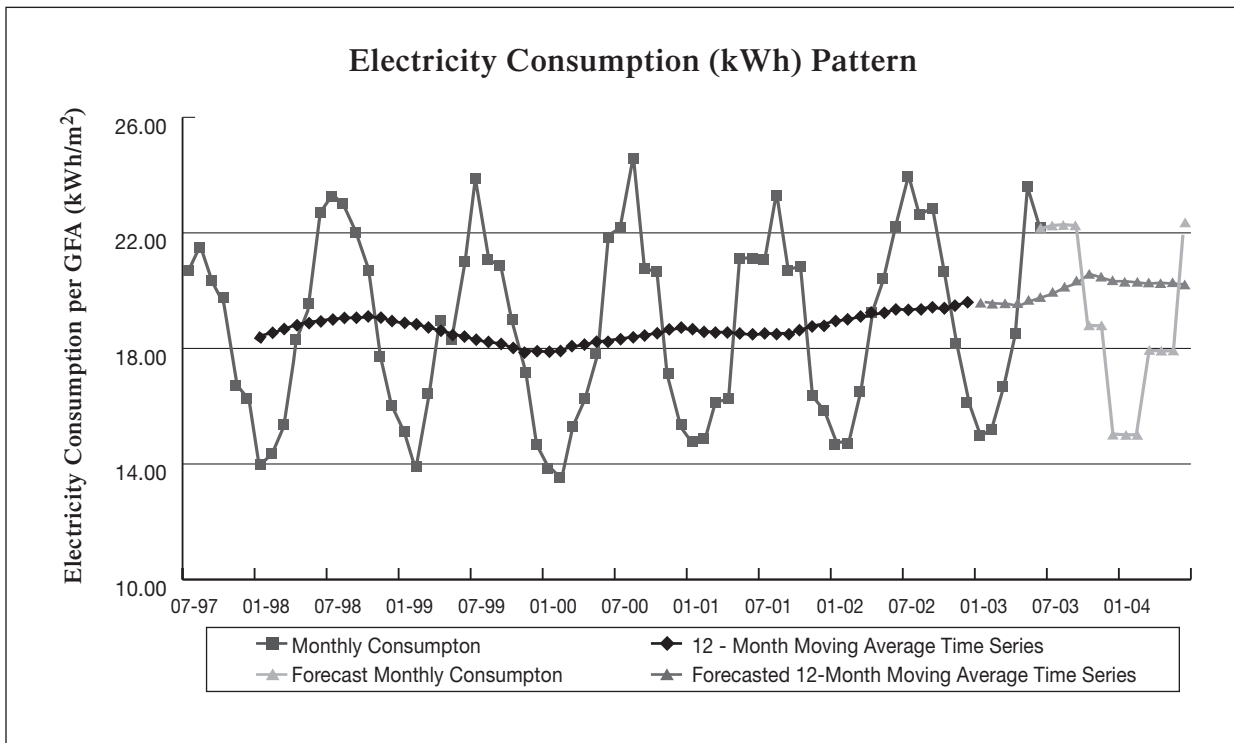

Figure 5 12-month ex-ante forecast for building T

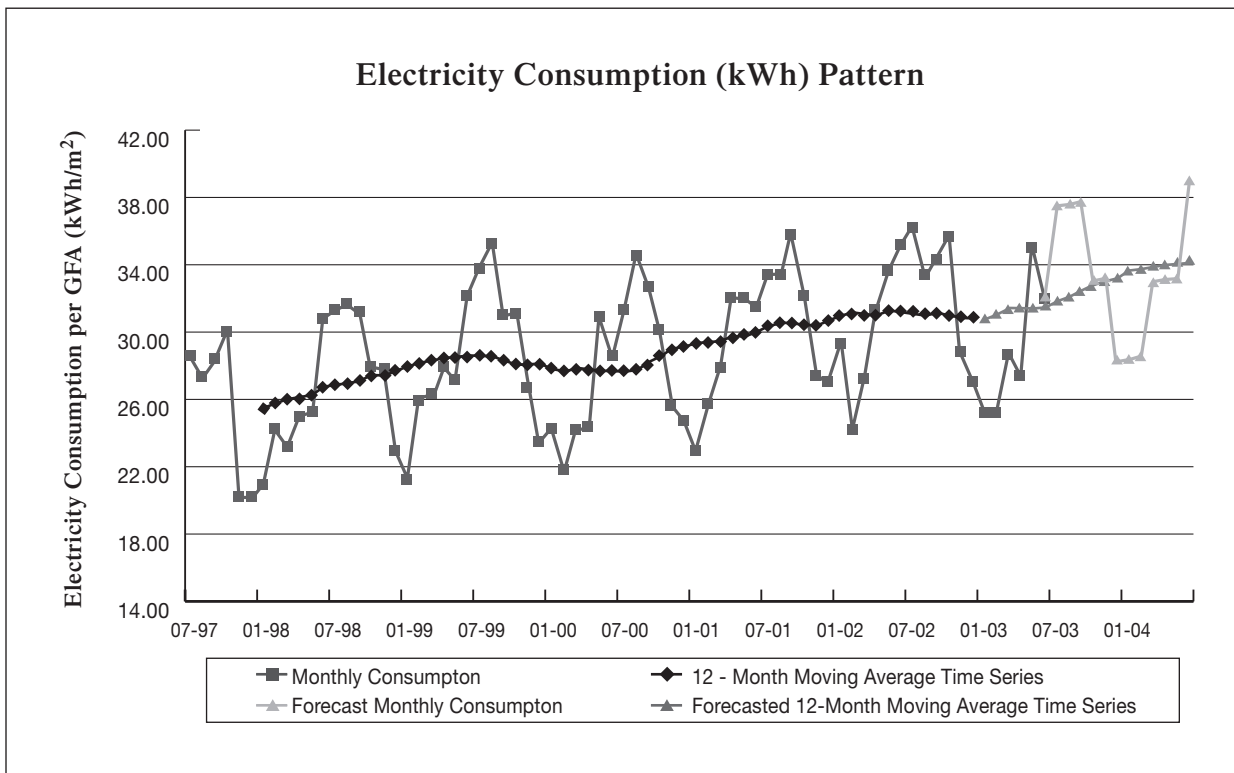

Table 5 shows provisions of extended periods of air conditioning in the buildings. The amounts are for years 2001-02 and 2002-03; the interviews confirm that such amounts are typical for the sampling period.

Table 5 extensions of standard A / C provisions

Building	24 hour A/C supply (by % GFA)	A/C supply 7pm to 11pm (by % GFA)
C	16	50
K	6	55
L	0	25
M	1	38
T	35	20

DISCUSSION

The interviews with estates officers and academics, selected for their expertise in use patterns and costs of buildings in operation and drawn from three universities in Hong Kong, confirm that design of the building envelope, design and efficiency of the building services, usage patterns of the buildings, and activities and behaviour of the users are the major 'internal' factors governing energy consumption in similar buildings. For the envelope, shape – as in external wall : floor ratio is important, coupled with solar gain (and shading) and the U-values of the envelope elements. Appropriate design, notably sizing, of the heating / cooling services to facilitate efficient operation, together with effective maintenance is essential for services provisions to be energy-efficient. Using regression modelling and computer simulation of climatic conditions, Li, Wong and Lam (2003) determined that HVAC provisions in office buildings in Hong Kong are over-sized, which results in wasting energy. Attention to maximise the use of natural lighting is important via window sizing and configuration (including 'trade-off' considerations for solar gain etc. and use of solar treated / intelligent glazing).

Use patterns of buildings and the impacts of peoples' activities and behaviour are very significant for energy consumption in buildings. Whilst common functions in similar sized and

located buildings (as in this study) act to reduce the differential effects of behaviour, some behavioural differences remain inevitable (e.g. engineering students and staff may behave differently from law students and staff in their uses of buildings - perhaps, partly due to their differential knowledge and to concerns over the consequences of their behaviour).

Mean ambient temperature and relative humidity have been incorporated into the models as the main 'external' factors. Solar radiation, and wind effects have not been included. It is well known that solar gain has an important impact on cooling loads of buildings; in this study, with proximate locations of the buildings and similar orientations and elevations, differential effects are believed to be low.

Over the modelling period (1997–98 to 2002–03), building T showed the greatest increasing trend of electricity consumption per GFA and consumed significantly more electrical energy than any of the other buildings. Buildings K and M showed slight increases, whilst building C showed a slight decrease and building L a greater decrease. The impact on building T of housing the art gallery and museum (requiring 24-hour air conditioning and dehumidification as well as much spotlighting), together with a high density of personnel and associated equipment in its office area and considerable prolongation of

standard duration of air conditioning provision, accounts for the high and increasing consumption of electricity over the period.

Building C contains about 35% GFA for research laboratories, which contain a lot of equipment and has prolonged demands for air conditioning, therefore, it has the second highest consumption of electricity per GFA. The lowest consumption level *appears* to be building K, however, the data for that building are distorted downwards because approximately 30% of the chilled water for air conditioning is supplied from the central plant, which is not measured separately and allocated to that building's energy consumption (hence, an increase in building K's energy consumption by 20-25% might be appropriate).

Between 1998 and 2002, the peak consumption of energy occurred during the summer – usually July or August – the hot and humid climatic conditions dominated reduction in use of the buildings. However, in 2003, the University introduced a number of energy reduction measures during the summer and so, peak consumption shifted to May for all five buildings. Generally, minimum consumption occurs in February – a winter month which includes the Chinese New Year holiday period of one week (as we as being a month of short duration). Building M shows the greatest variation between minimum and maximum monthly consumption and building T has least variation; that can be explained by the activities housed in that building (see above) and that it was constructed recently. Monthly

'seasonal' indices are shown in table 6.

Upgrading the chilled water plant system in building L at the end of year 2000, coupled with reduction of lighting levels, proved effective in reducing the electrical energy consumed.

As part of the measures to reduce energy consumption, many lecture rooms have been fitted with new controls which cannot be adjusted by individual users. On occasions, due to levels of occupation, the rooms are uncomfortable (often, too cold) which results in users switching off the air conditioning, where possible. Movement detectors have been fitted in some offices to ensure that lighting is switched off when the offices are unoccupied – given the nature of activities in such offices, those controls are not always suitable, thereby frustrating occupants and so, inducing them to 'circumvent' those controls (e.g. by use of small swing-fans).

Zoning of the HVAC provisions in buildings tends to cover quite large areas and so, the zones may be inappropriate to the sensitivity desirable to facilitate efficient control of the HVAC in the buildings. That is especially apparent when requests for extended times for HVAC operation are made - the provision for the entire zone must be extended even though the area being used may be only a small part of it. As an element of energy reduction measures, some offices have movement detectors which control air conditioning as well as lighting.

Table 6 *Monthly 'seasonal' indices*

Bg	Jan	Feb	Mar	Apr	May	Jun	Jul	Aug	Sep	Oct	Nov	Dec
C	0.78	0.76	0.88	0.98	1.06	1.14	1.20	1.18	1.12	1.11	0.93	0.85
K	0.73	0.71	0.87	0.95	1.13	1.21	1.20	1.16	1.14	1.13	0.94	0.83
L	0.77	0.77	0.90	0.97	1.07	1.13	1.14	1.15	1.13	1.13	0.98	0.85
M	0.70	0.68	0.80	0.93	1.06	1.23	1.31	1.31	1.20	1.12	0.89	0.77
T	0.83	0.86	0.90	0.98	1.03	1.09	1.15	1.16	1.13	1.08	0.93	0.85

Note: figures in italics are minima; figures in **bold** are maxima.

CONCLUSIONS

The buildings examined (in common with other buildings of the University) are subject to energy inefficiency due to over design of the HVAC systems plant, and of the lighting levels. Both of these issues are being addressed progressively through refurbishment of the buildings, and modification of the control systems. Further, the University is proactively executing a programme of enhancing awareness of users of its buildings to improve their energy use behaviour. However, the impact of the design of the buildings' envelopes on energy use is a more difficult problem – refurbishment work to enhance thermal insulation of buildings' envelopes is disruptive and not always cost-efficient.

The deterministic time series models are appropriate both to assist analysis of energy consumption and to forecast energy usage. The models clearly demonstrate the trends in energy usage in the University, and the major impact of (seasonal) climatic conditions on, most notably, energy consumption to operate HVAC. Variations between the models of individual buildings demonstrate the importance of different functions and levels of use on the energy requirements.

Overall, the measures taken by the University to reduce energy consumption are proving effective. However, the results do demonstrate that there remains much room for improvement. Only limited improvement can be made (cost) effectively and efficiently in occupied buildings. These findings emphasise the imperative of major analyses of energy consumption requirements during design – beginning at an early stage of design to ensure that the energy needed for the building to function well is minimised and that the designs are sensitive to different functions / user needs by acknowledging peoples' likely behaviour as well as the technology of building services provisions and the hardware of the envelope constructions.

REFERENCES

- Cole, RJ (1999) Building environmental assessment methods: clarifying intentions, *Building Research and Information*, **27**(4/5), 230-246.
- Cole, RJ, Kernan, PC (1996) Life-cycle energy use in office buildings, *Building and Environment*, **31** (4), 307-317.
- Gomez-Amo, JL, Tena, F., Martinez-Lozano, JA, Utrillas, MP (2004) Energy saving and solar energy use in the University of Valencia (Spain), *Renewable Energy*, **29** (5), 675-685.
- Graves, A, Sheath, D, Rowe, D, Sykes, M. (1998) Constructing the Best Government Client, Vol. 1, 'The Government Client Improvement Study' and Vol.2, 'The Pilot Benchmarking Study', London: H.M. Treasury Procurement Group.
- Lam, JC, Chan, RYC., Tsang, CL, Li, DHW (2004) Electrical use characteristics of purpose-built office buildings in subtropical climates, *Energy Conversion and Management*, **45** (6), 829-844.
- Li, DHW, Wong, SL, Lam, JC (2003) Climatic effects on cooling load determination in sub-tropical regions, *Energy Conversion and Management*, **44** (11), 1831-1843.
- Nicolini, D, Tomkins, C, Holti, R, Oldman, A, Smalley, M (2000) Can Target Costing and Whole Life Costing be Applied in the Construction Industry?: Evidence from Two Case Studies, *British Journal of Management*, **11**, 303-324.
- Scheuer, C Keoleian, GA, Reppe, P (2003) Life cycle energy and environmental performance of a new university building: modelling challenges and design implications, *Energy and Buildings*, **35** (10), 1049-1064.

World Commission on Environment and Development (1987) *Our Common Future* (the Brundtland Report), Oxford: Oxford University Press.

Yeomans, KA (1968) *Statistics for the social scientist*, Harmondsworth: Penguin.

An Empirical Study of the Relationship between Economic Growth, Real Estate Prices and Real Estate Investments in Hong Kong

LHT Chui and KW Chau¹

ABSTRACT

This study examines the lead-lag relationships between real estate prices, real estate investments, and economic growth. The results suggest that there is no relationship between GDP and real estate investment. This contradicts the results of similar previous studies in other economies. We propose that the lack of relationship is due to the significant variation in the project's duration in Hong Kong. The variation in project duration implies that the observed volume of real estate investment in any period represents the realization of investment decisions made at different points in time in the past.

The lack of a relationship between real estate investment and economic growth does not mean that changes in demand for real estate have no effect on economic performance. Since Hong Kong's real estate market is very efficient, changes in demand conditions in the real estate sector are reflected more accurately and quickly in real estate prices. Our empirical results show that real estate prices, especially office and residential prices, lead economic growth

The findings in this study have a number of implications. First, real estate prices, office and residential prices in particular, were found to lead GDP growth. Therefore, movements in real estate prices can be used to forecast GDP growth. Second, since real estate prices lead GDP, policies that stabilize residential prices are also likely to stabilize economic growth. Third, any policy that suppresses or deters the real estate sector, especially the residential sector, is likely to negatively affect economic performance. Similarly, any policy that stimulates real estate prices will also stimulate the economy.

In Hong Kong, the SAR Government has far more ability to influence real estate prices than aggregate demand, since the government is the only supplier of new developable land. For example, real estate prices will go up if land supply is restricted by the cessation of land sales, as investors would anticipate a lower supply of real estate units.

KEYWORDS

economic growth, leading indicators, real estate investment, real estate cycle

¹*Department of Real Estate and Construction, The University of Hong Kong, Pokfulam Road, Hong Kong.*

Fax No: (852) 2559 9457, E-mail: hrrbckw@hku.hk

INTRODUCTION

Hong Kong is a densely populated city. Because of the limited land supply here, the real estate sector has played an important role in Hong Kong's economy. This is evidenced by the fact that the real estate sector and construction industry contribute to more than 20 percent of Hong Kong's GDP. In addition, more than 45 percent of the local listed companies are either real estate developers or investors, or are heavily involved in real estate development and investment. More than one-third of total government income is derived from real estate. Given the importance of the real estate sector in Hong Kong's economy, it is interesting to know how real estate demand and economic performance are related. There are two ways to measure real estate demand : by real estate investments or real estate prices. When demand for real estate increases, prices will rise and investors will increase their investments in it to meet demand. Therefore, real estate prices and real estate investments are directly proportional to real estate demand.

In the United States, real estate investment is a good measure of expected demand for real estate. However, this may not be the case in Hong Kong. On the other hand, economic performance is reflected in the Gross Domestic Product (GDP). If there is a leading relationship between GDP, real estate investments, and real estate prices, the real estate sector will be a leading sector of economic performance. Therefore, real estate investments and prices are good measures for reflecting expected real estate demand, and serve as good predictors of economic performance. However, there has been little empirical study on the relationship between GDP, real estate prices, and real estate investments in Hong Kong. Moreover, the restricted land supply and various planning and development controls in Hong Kong complicate the investigation of this relationship. The need to use time series data in the investigation also makes an empirical study problematic.

LITERATURE REVIEW

Since estate investment is a major form of investment expenditure, it is expected that it will be closely related changes in GDP. Green (1997) uses the Granger Causality test to examine the effect of these two kinds of investment on GDP. They found that residential investment Granger causes (leads) GDP, while investments in equipment and machinery do not. Podenza (1988) also found that downturns in housing starts occur before general downturns. Both of them share the view that residential investment, like stock prices and interest rates, is a good predictor of GDP. This is because real estate is durable asset that take a long time to produce and thus investing in real estate is a forward looking exercise. For example, if participants in the housing market anticipate a future downturn in activity, housing activity may decrease first in anticipation of this. Households will not increase their expenditures on housing unless they expect the housing market to prosper in the future. The empirical observation that housing activity "leads" downturns and upturns may thus be simply a reflection of this anticipatory behaviour in the housing market.

Green (1997) proposes another explanation for residential investment being the leading indicator of GDP. This requires the consideration of potential "exogenous forces" in residential investment that lead to economically exogenous movements. These are the income tax treatment of residential investment and regulatory treatment of housing finance institutions. Green suggests, for example, that if residential investment is given special treatment under tax law through accelerated depreciation and the generous treatment of passive losses and gains, more capital will be attracted to residential investment. Then, people who build would be given high paying jobs, and there would be a reasonably large multiplier effect over a period of several years that stimulates economic growth.

Green's (1997) causality results are strengthened by Coulson and Kim (2000). Their study confirms that GDP's response to a shock in residential investment is several times the magnitude of a response to a shock in investment in equipment and machinery. They suggest that residential shock explains far more of the variation in GDP than does a shock in equipment and machinery. Coulson and Kim extend their study of the causality to the components of GDP : consumption and government expenditure. The results show that both equipment and machinery and residential investments are caused by every component of GDP, except that the former appear to cause consumption while the latter do not.

Coulson and Kim's explanation of the relationship between residential investment and GDP is somewhat different from what Green (1997) argues in his study. Residential investment evidently Granger-causes consumption expenditure, which is the largest component of GDP in their model, so residential investment has a large effect on GDP itself (Coulson and Kim 2000). Although they gave an explanation why residential investment leads GDP, the reasons why residential investment leads consumption expenditure were not discussed. Moreover, the focus of these two studies in the United States is mainly on residential investment, and there have seldom been studies on how other real estate investments affect economic growth. The explanation suggested by these studies also does not take into account how fast real estate investments can adjust to a shakeup in the economy.

For studies on non-residential buildings and structures investment, Madsen (2002) adopted models that were based on the relative importance of demand and supply in prices and quantities. His test used a pooled cross section and time series data of 18 countries from 1950 to 1999. Madsen argues that if supply side factors have been more important for investment while demand side factors have not, then the causality direction goes from investment to economic growth, and vice versa. The results show that supply factors are not crucial to building investments, and building

activity is predominantly driven by demand. Therefore, Madsen suggests that investment in non-residential buildings and structures is predominantly caused by economic growth.

In fact, there have been other studies on the relationship between real estate investment and the economy. Two of the most notable contributions arrived at virtually opposite conclusions. Aschauer (1989) argues, using a growth accounting framework for post-war U.S. data, that public infrastructure investment – virtually all of which is building investment – is a key component of growth, and that much of the post-1973 productivity slowdown can be attributed to cutbacks in public capital investment. On the other hand, DeLong and Summers (1991, 1992) and DeLong (1992), suggest that building investment has a negligible relationship with growth using purchasing power parity adjusted data. They even find a negative social return to investment in buildings. Ball and Wood (1995) report evidence of strong co-integrating relationships between productivity levels and fixed investment in both equipment and structures in the United Kingdom over the past 140 years. There is strong evidence of two-way Granger causality prior to 1938 between productivity levels and virtually all sub-categories of investment. For the postwar period, a long run error correction mechanism for productivity levels and equipment and structures investment is indicated when these are considered separately (Ball and Wood, 1995).

A similar study using the Granger Causality Test to investigate the lead-lag relationship between construction activity and the aggregate economy was conducted in Hong Kong by Ganesan and Tse (1997). The performance of the aggregate economy is proxied by GDP, while construction activity is measured using construction flow, which refers to new construction works and renovation and maintenance. The value of work put in place was measured from progress payments received during the reference period. However, the construction flow was not categorized into residential or commercial investment. Also, both GDP and construction flow are measured at

current prices (i.e., price changes were not taken into account).

The results of Ganesan and Tse's study demonstrate strongly that GDP tends to lead construction flow, but not vice versa, which is in contrast to the results of research in the U.S. and the U.K. Ganesan and Tse (1997) claim that the relationship between construction flow and GDP is analogous to the saving-income relationship. The national income identity does not imply that an increase in saving will lead to a higher GDP. It is believed that the initial impact of a change in GDP would be on the demand for construction projects and real estate rather than on the level of construction output because construction activity is very sensitive to credit conditions. If GDP rises, so will the level of construction activity needed to meet the expanded production capacity.

Ganesan and Tse (1997) also compare the volatility of construction flow and that of GDP. They show that construction flow is more volatile than GDP. Ball and Morrison (1995) argue that all types of fixed investment are considerably more volatile than national income. It is expected that short term growth rates of construction can easily fluctuate a lot due to changes in capacity utilization. Akintoye and Skitmore (1994) suggest that construction is a derived demand that is growth dependent. If markets are interdependent, disturbances in one market will be transmitted to other markets (Ganesan and Tse, 1997).

From these studies, there are two contrasting views on the lead-lag relationship between construction investments and GDP. Some hold the view that construction investments, especially residential investments, stimulate consumption and economic growth, and therefore residential investments lead GDP. On the other hand, some believe that construction activity is a derived demand that depends on economic performance, and thus they conclude that GDP leads real estate investments. However, most of the studies have focused on residential investments or real estate investments as a collective term without looking at how GDP affects each type of real

estate investment separately.

GDP and Real Estate Prices

Englund and Ioannides (1997) compare the dynamics of housing prices in 15 countries, and discover that lagged GDP growth exhibits significant predictive power over housing prices. Hui and Yiu's (2003) study, which uses the Granger Causality Test to empirically test the market fundamental dynamics of private residential real estate prices in Hong Kong, confirms this result. It has been shown that residential prices lead GDP from 1984:Q1 to 2000:Q4, but not the opposite. The following reason is suggested by Hui and Yiu: GDP represents an overall change in the economy, and is regarded as one of the market fundamentals that affect demand for private residential real estate. Also, GDP is affected by some market fundamentals. Since both price and GDP are expectation driven, they lag behind the release of information for market fundamentals.

At the same time, GDP is affected by residential prices (Hui and Yiu 2003). Another study done by Chau and Lam (2001) on speculation and property prices in Hong Kong reveals that nominal GDP is a leading indicator of housing price. The model which Chau and Lam used included the real interest rate, the percentage change in the lagged housing price, the marriage rate, the stock market index, housing supply, transaction volume, and an error correction term in order to control for other factors affecting housing prices. Nominal GDP is used in the model to capture the effects of inflation and economic growth, while housing price is the official residential index compiled by the Rating and Valuation Department (RVD). Chau (2001) suggest that due to the high land price policy and importance of the property sector in Hong Kong, its economic performance has been dependent on the performance of the property market, which means that property price leads economic growth and drives inflation.

Iacoviello (2003), in his study of consumption, housing prices, and collateral constraints, find a direct effect from housing prices to consumption

using the Euler equation for consumption. Then, according to Coulson and Kim (2000), as consumption forms a large part of GDP, it is reasonable to expect that housing prices will have a leading relationship to GDP.

Although the above mentioned studies have shown that GDP leads housing price, the main focus of these studies is not to investigate the relationship between GDP and housing price. Moreover, in Hui and Yiu's (2003) paper, the housing price used is in nominal terms rather than in real terms. This nominal housing price is used to investigate its relationship to constant GDP. In Chau's (2001) study, nominal GDP is used to investigate its relationship to the residential price index. There has been no study that has researched the relationship between real GDP and real estate prices. In most studies, only residential price has been investigated. There has also been no research done on the relationship between GDP and other property prices.

DiPasquale and Wheaton (1992) have shown that stock adjustment is much slower than price adjustment in real estate market when there is an external shock. Their results suggested that the stock coefficient in their model, which represents the speed in which the stock adjusts through new construction, was two percent, while that of the price coefficient was much higher, meaning that the price adjusts much faster than the stock. Therefore, it is not surprising that any external shock to the economy will be reflected in price first.

Ganesan et. al. (1999) supports the idea that housing price is a leading indicator of housing supply. They observed that housing demand in Hong Kong dropped instantly after the Tiananmen Square incident in 1989 and the Gulf War in 1991, but housing supply was only adjusted in the years following these incidents. They therefore suggested that there is a lag effect on the adjustments of housing supply. The short run supply of housing is also fairly inelastic because housing supply is based on current completions that will continue, and cannot be changed within

a short period of time. Unlike housing supply, it is possible for housing demand to change suddenly due to external changes. Ganesan et. al. agrees that fluctuations in demand should manifest themselves primarily in changes in the price of housing and much less so in the supply of housing.

RESEARCH ISSUES

Does Real Estate Investment Lead GDP?

Green (1997) and Coulson and Kim (2000) have shown that residential investment is a leading indicator of GDP in the United States. Their result suggest that the residential sub-sector is a leading sector of the economy, and that changes in housing demand are ahead of changes in aggregate demand. Green (1997) proposes that this trend is due to forward looking behaviour (the forward looking effect) and the potential "exogenous forces" in residential investment that lead to the economically exogenous movements (the external shock effect). These forces are the income tax treatment of residential investment and regulatory treatment of housing finance institutions. If residential investment is given favourable tax treatment, more capital will be attracted and people will be given high-paying jobs. When people become wealthier, they will spend more and stimulate economic growth (the wealth effect). Therefore, an increase in residential investment will lead to economic growth (this is in contrast to the "income effect," which suggests that people's demand for housing increases when their incomes increases). This explanation is confirmed by Coulson and Kim (2000). They find that residential investment actually Granger causes private consumption, which is the largest component of GDP. Therefore, it can be said that any external shock will be reflected in the demand for real estate first, which will be reflected in residential investments in the U.S. Given that the changes in real estate investment reflects changes in demand for real estate, the "wealth effect" implies that residential investment leads GDP, while the "external shock effect" and "forward looking effect" imply that the non-residential sector investment, (i.e., office,

retail, and industrial buildings) will also lead GDP.

Unlike the US, real estate investment in Hong Kong is unlikely to be a good predictor of GDP. This is mainly because of the differences in the land development processes between the two places. Unlike the U.S., Hong Kong is a densely populated city with a limited supply of land. The government is the sole owner of all land in Hong Kong. It has a monopoly over the release of new and previously undeveloped land through the leasehold land tenure system. Thus, land development is not at the sole discretion of developers in Hong Kong. Rather, it is subject to numerous supply and development controls. Developers have to bid for land in land sales, apply for planning applications or lease modifications for redevelopment, or purchase land with multiple owners. Therefore, there is a significant time lag between the decision to invest (triggered by an increased demand) and the actual realization of the investment. More importantly, the time lag varies significantly depending on the scale of development, type of real estate, location, and other characteristics.

The land development period in Hong Kong is much longer than that in the U.S. A decision to develop may be made a few years before actual construction takes place because in Hong Kong, real estate investments in one time period are actually a mix of development decisions made during different time periods that present different demands. The level of real estate investments in one time period cannot reflect a just-in-time demand for real estate. This is in contrast to the situation in the U.S., where single house developments are common and developers are subject to fewer planning and development controls. The time lag between the decision to invest in residential real estate and the actual realization of such an investment is relatively uniform and not too long in the U.S.

The major part of real estate investment expenditure is construction cost. However, construction cost only constitutes about 30% of a typical development (due to high land prices in

Hong Kong). This means that once a project has started, it is more economical to finish it even if demand for it has declined significantly.

Do Real Estate Prices Lead GDP?

Previous studies suggested that real estate prices (in particular residential prices) are leading indicators of GDP (e.g. Chau, 2001). This is the case in Hong Kong, since real estate prices reflect changes in demand for real estate more quickly. In addition, a high land price policy and the significance of real estate in Hong Kong make its economy dependent on the performance of the property market. The major form of wealth for most Hong Kong people is their homes. On average, the value of a residential unit is worth more than 20 years of an average homeowner's real household income. This means that the "wealth effect" is likely to be more important in Hong Kong.

Previous studies also suggested that Hong Kong's real estate market (especially the residential market) is very efficient. If the real estate market is efficient, it is reasonable to expect that any external shock will be reflected in real estate prices faster than in the GDP.

Moreover, investors / developments' forward looking behavior will also be reflected in changes in real estate prices. If an investor foresees an increase in demand, his / her decision to invest in real estate will drive prices up, and such changes in real estate prices will lead economic growth.

Amongst all the real estate sub-sectors : residential, office, retail, and industrial, residential price is expected to show the strongest leading relationship to GDP due to its considerably larger volume of transactions than the other sub-sectors. Residential properties constitute more than 80% of all property transactions in Hong Kong.

Do Real Estate Prices Lead Real Estate Investments?

Since the level of real estate investments cannot be increased or decreased overnight in Hong Kong, neither can it adjust itself immediately after an external shock. Housing demand in

Hong Kong dropped instantly after the 4 June 1989 incident and the Gulf War in 1991, but housing supply only adjusted in the years following these incidents (Ganesan, et. al., 1999). Thus, it is reasonable to expect that real estate price movements are ahead of real estate investments. However, since the lead times for different projects vary significantly, there may not be any observable lead-lag relationship between real estate prices and real estate investments.

DATA

The data series for testing the lead-lag relationships between economic growth, real estate investment, and estate prices of different sub-sectors were obtained from the RVD and the Census and Statistics Department of the Hong Kong SAR Government. Economic growth was measured by growth in de-seasonalized GDP in real terms. The real estate sub-sectors investigated were the residential, office, retail, and industrial sub-sectors.

The RVD price indices were compiled based on transaction evidence. The reliability of a transaction based index depends on the trading volume and the method of controlling for those attributes that influence price. In Hong Kong, the volume of real estate transactions in relation to

the size of the total stock of real estate is relatively high compared to most other cities. The high trading volume is attributable to the dynamic nature of Hong Kong's economy and simple taxation system. There is no capital gains tax, and transaction costs are relatively low (Brown and Chau, 1997). The small size of Hong Kong and the relatively short economic life of buildings tend to reduce any error in the price index from arising due to possible bias caused by adjusting average transaction prices for differences in those factors that affect price. Moreover, the mortgage policy adopted by most banks in Hong Kong discriminates against older buildings (Chau and Ma, 1996). More favourable terms will normally be given to buildings not more than ten years old. The result of this policy is that most properties transacted in the market are less than ten years old. These factors tend to make the market more homogeneous (Brown and Chau, 1997).

Real estate investments are divided into two categories (i.e., residential and non-residential investments). These investments are further divided into public and private investments. Real estate price indices for the residential, office, retail, and industrial sub-sectors are available and used in this study. All data is quarterly time series data. These variables and their symbols are listed in Table 1. The summary statistics of the variables presented in Table 2.

Table 1 Symbols of the Time Series Variables

Variable	Symbol
GDP in Real Terms	GDP_R
Residential Price	RP
Office Price	OFFP
Retail Price	RETP
Industrial Price	INDP
Private Residential Investment	RIPR
Public Residential Investment	RIPU
Private Non-residential Investment	NIPR
Public Non-residential Investment	NIPU

Table 2 Summary of Statistics of the Variables in Level Terms

Variable	Minimum	Maximum	Mean	Std Dev
GDP_R	18.30	109.70	58.69	27.70
RP	15.20	433.00	138.94	111.72
OFFP	24.00	230.00	95.78	58.68
RETP	35.00	413.00	154.11	100.66
INDP	36.00	192.00	91.81	47.09
RIPR	19.54	103.43	53.45	23.84
RIPU	3.43	102.22	37.80	21.38
NIPR	41.18	311.95	154.76	61.32
NIPU	5.47	160.35	61.12	35.48

Real estate price indices were obtained from the RVD. The indices are the composite quarterly index for a certain type of premises. Types of private sector premises include residential, office, retail, and industrial. The composite quarterly index is compiled by calculating a weighted average of the component indices (the indices for a property class or grade) that have been derived from an analysis of all transactions effective in a given quarter. The premises are categorized according to the use for which the occupation permit was originally issued. The indices measure value changes by reference to the factor of price divided by the rateable value of the subject properties such that allowance is not only for made for floor area, but also other qualitative differences between properties.

The real estate investments were obtained from the expenditure GDP series. They are major

components of investment expenditure, and classified into private and public sectors. Under each sector, the real estate investments were further categorized into residential and non-residential buildings. Real estate investment includes payment to contractors and other expenses directly related to property developments, architectural design, and technical consultancy services.

The data series are tested for seasonality and stationarity. Granger causality test are then performed to test for lead-lag relationship.

EMPIRICAL RESULTS

The Augmented Dickey-Fuller (ADF) Test showed that the deseasonalized trend was I(1). Table 3 shows the ADF test statistics. The optimal lag is 4 for all series.

Table 3 Results of the Unit Root Test on growth rates

Variable	1 Lag	2 Lag	3 Lag	4 Lag
GDP_N	-6.04*	-5.14*	-7.46*	-7.92*
GDP_R	-9.81*	-5.82*	-4.40*	-4.65*
RP	-5.16*	-5.91*	-8.36*	-5.90*
OFFP	-4.77*	-4.40*	-6.30*	-4.71*
RETP	-5.00*	-5.18*	-7.31*	-4.64*
INDP	-5.09*	-3.10	-5.21*	-8.05*
RIPR	-8.55*	-5.61*	-7.06*	-7.48*
RIPU	-8.02*	-5.89*	-7.22*	-6.84*
NIPR	-6.66*	-5.70*	-8.27*	-5.87*
NIPU	-8.41*	-5.82*	-8.05*	-8.05*

* MacKinnon critical values for the rejection of the hypothesis of a unit root at 1%

** MacKinnon critical values for the rejection of the hypothesis of a unit root at 5%

*** MacKinnon critical values for the rejection of the hypothesis of a unit root at 10%

The Granger Causality Test

The Granger Causality Test was first performed with six lags, according to the experimental results in Guilkey and Salami (1982). The test was then performed with four lags and five lags to confirm the robustness of the results. Table 4 shows the results of the Granger Causality Tests on real GDP and Real Estate Investments

The p-values of the Granger Causality Test on each pair of variables were higher than 0.1, except on GDP_R and NIPR. This meant that

most of the null hypotheses could not be rejected, except for the null hypothesis "GDP_R does not Granger cause NIPR". Hence, there was no evidence that real estate investment leads GDP. The result was quite robust and not sensitive to the choice of lags around the optimal lag. The results were different from those in the U.S., but were within expectations. The results confirmed that real estate investments are not good leading indicators of economic performance.

Table 4 Results of the Granger Causality Test on GDP_R and Real Estate Investments

	4 Lag	5 Lag	6 Lag
	Probability	Probability	Probability
GDP_R does not Granger RIPR	0.93514	0.92038	0.95474
RIPR does not Granger cause GDP_R	0.23183	0.15155	0.20874
GDP_R does not Granger cause RIPU	0.39756	0.39569	0.21699
RIPU does not Granger cause GDP_R	0.71888	0.63397	0.53636
GDP_R does not Granger cause NIPR	0.01546*	0.01053*	0.01998*
NIPR does not Granger cause GDP_R	0.12168	0.24060	0.64147
GDP_R does not Granger cause NIPU	0.72259	0.87575	0.90557
NIPU does not Granger cause GDP_R	0.98664	0.97099	0.96844

* Rejection of the null hypothesis

Table 5 shows the result of the Granger Causality Test between real estate prices and GDP. The result shows that GDP_R was Granger caused by RP and OFFP, but not vice versa. No lead-lag relationship was found between RETP and GDP_R. These results were within expectations. Residential price and office price are both leading indicators of economic growth.

Table 5 Results of the Granger Causality Test on GDP_R and Real Estate Prices

	4 Lag	5 Lag	6 Lag
	Probability	Probability	Probability
RP does not Granger cause GDP_R	0.05366*	0.02881*	0.02703*
GDP_R does not Granger cause RP	0.74581	0.51182	0.16580
OFFP does not Granger cause GDP_R	0.01057*	0.00051*	0.01286*
GDP_R does not Granger cause OFFP	0.34834	0.45330	0.51047
RETP does not Granger cause GDP_R	0.39362	0.48037	0.59321
GDP_N does not Granger cause RETP	0.30130	0.27993	0.41169
INDP does not Granger cause GDP_R	0.09771*	0.07661*	0.13992
GDP_R does not Granger cause INDP	0.16211	0.15080	0.21575

* Rejection of the null hypothesis

Table 6 shows the results of the Granger Causality Test on Real Estate Prices and Real Estate Investments. Most p-values obtained from the Granger Causality Test were greater than 0.1, indicating that most null hypotheses could not be rejected at all lags. There were some exceptions to the results. Both RETP and INDP led NIPR, and the feedback relationship did not exist. The results were again within expectations due to variations in the lead time for different project types.

Table 6 Results of the Granger Causality Test on Real Estate Prices and Real Estate Investments

	4 Lag	5 Lag	6 Lag
	Probability	Probability	Probability
RP does not Granger cause RIPR	0.44152	0.44152	0.58055
RIPR does not Granger cause RP	0.55571	0.55571	0.63249
RP does not Granger cause RIPU	0.79040	0.84357	0.68586
RIPU does not Granger cause RP	0.39196	0.44160	0.43098
OFFP does not Granger cause NIPR	0.34358	0.30734	0.40619
NIPR does not Granger cause OFFP	0.91944	0.87196	0.93372
OFFP does not Granger cause NIPU	0.12151	0.22224	0.29134
NIPU does not Granger cause OFFP	0.96964	0.95933	0.95859
RETP does not Granger cause NIIPR	0.09951*	0.06236*	0.10413
NIPR does not Granger cause RETP	0.95010	0.96498	0.96629
RETP does not Granger cause NIPU	0.83151	0.87904	0.84446
NIPU does not Granger cause RETP	0.62168	0.66169	0.63908
INDP does not Granger cause NIPR	0.13279	0.03451*	0.04634*
NIPR does not Granger cause INDP	0.77895	0.70503	0.52675
INDP does not Granger cause NIPU	0.18812	0.31207	0.40611
NIPU does not Granger cause INDP	0.97459	0.94748	0.78960

* Rejection of the null hypothesis

CONCLUSION

This study examined the lead-lag relationships between real estate prices, real estate investments, and GDP. The results suggested that during the period 1973:Q1 to 2003:Q2, there was no relationship between GDP and real estate investments. This contradicted the findings by Green (1997) and Coulson and Kim (2000), which used data from the United States. This was, however, consistent with our expectations. Due to the time lag between the decision to invest in real estate and the realization of the investment that varies significantly across development projects in Hong Kong, the observed real estate investment during any period represents a realization of a mix of investment decisions made at different points in time with significant variations in demand conditions. This makes real estate investments inappropriate measures of expected demand for real estate, and thus are poor predictors of GDP.

This result was further supported by the Granger Causality Test on the relationship between real estate prices and real estate investments, which showed no lead-lag relationship between prices and the volume of investment of different types of real estate. This provides further evidence that real estate investments are not good measures of a market's expected demand for real estate at any point in time. This however, does not mean that real estate demand has no effect on economic performance. Since Hong Kong's real estate market is very efficient, changes in demand are reflected more accurately and quickly in real estate prices. The Granger Causality Test results show that real estate prices, especially residential price, exhibit a strong leading relationship with GDP.

The findings in this study have important policy implications. Real estate prices, residential prices in particular, were found to lead GDP. Therefore,

movements in residential prices can be used to forecast GDP growth. Second, since residential prices lead GDP, policies that stabilize residential prices will also stabilize economic growth. Third, any policy that suppresses or deters the real estate sector, especially the residential sector, is likely to negatively affect economic performance. Similarly, any policy that stimulates real estate prices will also stimulate the economy.

In Hong Kong, the SAR government has far more influence on residential prices than on aggregate demand through its land supply and housing policies. For example, residential prices will go up if land supply is restricted by the cessation of land sales, as investors anticipate a lower supply of residences in the future. Also, the cessation of public housing construction will increase demand for private housing because of the substitution effect, which will, in turn, increase residential prices. However, the government has less power to influence aggregate demand through monetary policy due to the current board system. Moreover, according to Article 107 of the Basic Law, the SAR is required to maintain a balanced budget. Thus, it is also difficult for the government to influence aggregate demand through fiscal policy. In order to minimize the effects of external shocks and maintain sustainable stable economic growth in the long run, the government should aim to stabilize real estate prices.

Due to insufficient observations after 1997, it is not possible to test the presence of structural breaks in this study. This is a potential area for further study in the future when more observations are accumulated. A structural break test can be performed to investigate if there has been any structural break. In addition, the RVD indices can be replaced by transaction-based indices that are constructed using the repeat sales or hedonic pricing models. A further area for research is the investigation of leading indicators of real estate prices.

REFERENCES

- Akintoye, A. and Skitmore, M 1994. Models of UK private sector quarterly construction demand. *Construction Management and Economics*, **12** (1), 3-13.
- Aschauer, D 1989. Is public expenditure productive? *Journal of Monetary Economics*, **23**, 177-200.
- Ball, M and Morrison, T 1995. Housing Investment fluctuations : an international comparison. Paper presented to "The Cutting Edge", 1-2 September 1995, Department of Land Economy, University of Aberdeen.
- Ball, M and Wood, A 1995. Does building investment affect economic growth? *Journal of Property Research*, **13**, 99-114.
- Brown, G and Chau, KW 1997. Excess returns in the Hong Kong commercial property market. *Journal of Real Estate Research*, **14**(1), 91-106.
- Chau, KW and Lam, H.M. 2001. Speculation and property Prices - Empirical evidence from historical price trends in Hong Kong. In: *the Asian Real Estate Society (AsRES) 6th Annual Conference, 1-3 August 2001. Tokyo Japan*.
- Coulson, NE and Kim, MS 2000. Residential investment, non-residential investment and GDP. *Real Estate Economics*, **28**(2), 233-247.
- DeLong, JB 1992. Productivity growth and machinery investment: A long-run look, 1870-1980. *Economic History Review*, **52**, 307-324.
- DeLong, JB and Summers, L.H. 1991. Equipment investment and economic growth, *Quarterly Journal of Economics*, **106**, 445-502.
- DeLong, JB and Summers, LH 1992. Equipment investment and economic growth: How strong is the nexus? *Brookings Papers on Economic Activity*, **2**, 157-211.
- Dickey, D and W Fuller. 1979. Distribution of the estimators for autoregressive time series with a unit root. *Journal of the American Statistical Association*, **74**(366), 427-431.
- DiPasquale, D and Wheaton, W.C. 1992. The markets for real estate assets and space: A conceptual framework. *Journal of American Real Estate and Urban Economics Association*, **20**(1), 181-197.
- Engle, R and C Granger. 1987. Co-integration and error correction: representation, estimation, testing. *Econometrica*, **55**(2), 251-276.
- Evans, P, Torto, RG, Wheaton, WC 1997. The cyclic behaviour of the Greater London office market, *Journal of Real Estate Finance and Economics*, **15**(1), 77-92.
- Ganesan, S and Tse, RYC. 1997. Causal relationship between construction flows and GDP: Evidence from Hong Kong. *Construction Management and Economics*, **15**, 371-376.
- Ganesan, S, Ho, CW and Tse, RYC. 1999. Matching housing supply and demand: An empirical study of Hong Kong's market. *Construction Management and Economics*, **17**, 625-633.
- Granger, C 1969. Investigating causal relationships by econometric models and cross-spectral methods. *Econometrica*, **37**(3), 424-438.
- Green, RK 1997. Follow the leader: How changes in residential and non-residential investment predict changes in GDP. *Real Estate Economics*, **25**(2), 253-270.
- Guilkey, D and M. Salemi. 1982. Small sample properties of three tests for Granger-Causal ordering in a bivariate stochastic system. *Review of Economics and Statistics*, **64**(4), 668-680.
- Hamilton, JD 1994. *Time Series Analysis*. Princeton, NJ: Princeton Publishers.

Hong Kong Census and Statistical Department.
Estimates of Gross Domestic Product, various issues.

Hong Kong Rating and Valuation Department.
Hong Kong Property Review, various issues

Hui, ECM and Yiu, CY 2003. Market dynamics of private residential real estate price – an empirical test in Hong Kong. *Journal of Financial Management of Property and Construction*, **8**(3), 155–165.

Iacoviello, M 2003. Consumption, house prices and collateral constraints: A structural economic analysis, *Journal of Housing Economics*, **13**(4), 304-320.

MacKinnon, JG 1991. Critical values for cointegration tests. In: Engle, R. F. and Granger, CWJ ed. *Long-run Economic Relationships*. Oxford: Oxford University Press.

Madsen, J 2002. The causality between investment and economics growth. *Economics Letters*, **74**(2), 157–63.

Bureaucracy and Red Tape in Public and Private Construction Project Organizations

BC Lam and AMM Liu¹

ABSTRACT

Projects are commissioned by public and private client organizations which have different organizational culture and structures that dictate the rules and procedures to be followed in project procurement. The research objective in this study is to examine the extent of bureaucracy and red tape in construction project organizations in the public and private sectors. The long perceived assumption that the public organizations are more bureaucratic than private organizations is found to be supported.

KEYWORDS

bureaucracy, red tape, construction project organizations

INTRODUCTION

Construction project organizations are often referred as temporary multi-organisations (Cherns and Bryant, 1984) and shifting multi-goal coalitions (Liu and Walker 1998, Newcombe 1994). Temporariness is emphasized in the sense that participants join the project organizations only for the duration of the project; after which they depart and join other project organizations. Moreover, a project participant may be a member of a few project organizations at any point in time. Such temporary organizational membership may affect the individual's perceived extent of bureaucracy of the organizations to which they belong. Thus, comparison of bureaucracy and red tape in construction project organizations may provide further support to the literature of bureaucratic public administration.

RESEARCH RATIONALE AND OBJECTIVE

It is claimed that the difference between public and private organization is mainly due to ownership, funding and control (Niskanen, 1971; Walmsley and Zald, 1973; Dahl and Lindblom, 1953). Public sector is often seen as more bureaucratic. The distinction of *publicness* has a wide range of implications and effects on the public and private organizations (Boyne 2002; Allison, 1979; Antonsen and Jorgensen, 1997; Bozeman, 1987; Fottler, 1981; Metcalfe, 1993; Newman and Wallender, 1978; Rainey, 1989; Ring and Perry, 1985; Stewart and Ranson, 1988) in terms of organizational environments, organizational goals, organizational structures and values of managers. It is the organizational structure that often relates to bureaucracy and red tape. According to Boyne (2002), the internal characteristics of public agencies can be viewed as more bureaucratic and having more red tape because of the government's inherent *sovereign political authority and breadth of mission*.

¹Dept. of Real Estate and Construction,
The University of Hong Kong.

However, Boyne's (2002) review of a number of studies on the impact of publicness on organizational structure is not entirely conclusive that public sector's bureaucracy and red tape are over that of the private sector. Furthermore, although there seems to be strong supports to say that public organizations are more bureaucratic than private organizations, public organizations do not necessarily have more red tape than private organizations.

In light of the above findings, the research objective in this paper is to compare the bureaucratic and red tape features in construction project organizations in the private and public sectors.

BUREAUCRACY AND RED TAPE

According to Mouzelis (1975), an understanding of Weber's (1947) theory of domination would be instrumental to the understanding of bureaucracy. Mouzelis (1975) suggests that bureaucracy is the typical administrative apparatus corresponding to legal (legitimate) domination and has many distinct characteristics, e.g., high degree of specialization, hierarchical authority structure with limited areas of command and responsibility, impersonality of relationships between organizational members, recruitment of officials on the basis of ability and technical knowledge, and differentiation of private and official income (Weber, 1947; Mouzelis, 1975; Bozeman, 2000).

Although it is claimed by Weber (1947) that bureaucracy is the most efficient type of organization, there is also a large amount of literature criticizing bureaucracy. The best known critical commentary is provided by Merton (1940) whose proposition is that bureaucracy excessively requires people to adhere to rules and procedures. Moreover, some (if not all) of those rules may become meaningless in the face of rapid environmental changes, i.e., the original purpose of setting those rigid rules may have become redundant as a result of changes in environment so that a rule may become an end in itself.

Thompson (1961) is of the opinion that the exaggeration of bureaucracy in modern organization is due to personal insecurity and people's need to control (which results from the gap between the rights of authority and the specialized ability of skills required to solve most organizational problems, e.g., the person in authority may not have the required skills and cause a sense of his/her insecurity, thus giving rise to an urge for tighter control). It is also claimed by Crozier (1964) that there is a vicious circle of bureaucracy dysfunctions. Bureaucracy can produce some dysfunctional effects including inflexibility, red tape, indifference, insensitivity, officiousness and blockage of information flow (Beetham, 1987). Red tape refers to delays as a result of excessive rules and procedures causing irritation and vexation as a consequence (Bozeman, Reed, and Scott 1992; Bozeman and Scott, 1996) and impose constraints by rules and procedures (Bozeman, 1993; Scott and Pandey, 2000). Often researchers assume that red tape has a strong negative effect on the normal operation of organizations.

It is also claimed by Sanders (1997) that all three features of bureaucracy, namely hierarchy, depersonalization and bureaucratic rules, have negative effects on modern organizations. The vicious circle of dysfunctions begins with impersonal rules, which leads to centralization of discretionary decisions by removing most discretion from officials. Detailed rules and regulations and those centralized decisions that cover the few matters not embraced by the rules give rise to hierarchical strata of power and authorities. The weakness of the command line may cause non-hierarchical or parallel power relationships to emerge where rules cannot cover unforeseen events. The parallel power relationships trigger demand for new rules and greater centralization of decisions, further weakening the line of command and opening new areas for the exercise of non-hierarchical influences. Crozier's (1964) model predicts that increased rules, centralization, non-hierarchical strata isolation, and parallel power will occur and

will lock bureaucracies into patterns of ever greater rigidity. Rather than changing with the environment, the nature of bureaucracy is change-resistant until a crisis of overwhelming proportion occurs.

METHODOLOGY

The following hypothesised relationships are tested:–

H1: The public project organizations have a higher degree of bureaucracy than private project organizations.

H2: The public project organizations have a higher degree of red tape than private project organizations.

The research plan comprises two parts: (1) the first part is to compare the perceived extent of bureaucracy and red tape by project participants in the public and private project organizations; (2) the second part adopts an objective case study of a public client organization and a private client organisation to cross-validate the result from the first part.

The identified sample for the questionnaire survey in part 1 includes those construction managers and architects who have experiences in both public housing projects and private residential development projects. The approved list of Housing Authority Building Contractors provides the contacts of construction managers. The architects are identified from the list of Hong Kong Institute of Architects. The personnel from client's organization are not included in the sample due to possible bias tendency.

Self-administered questionnaire method is adopted. The operationalization of bureaucracy adopted in this paper to examine public and private project organisations in construction relies on the five features of bureaucracy suggested by Bozeman and Rainey (1998)

and Rainey, Pandey and Bozeman (1995): (1) hierarchy, (2) specialization, (3) approvals needed to perform a task, (4) written rules and procedures, and (5) record keeping. The operationalization of red tape adopted in this paper is provided by Rainey, Pandey and Bozeman (1995) which comprises four dimensions: (1) global measure, (2) personnel measure, (3) administrative-delay measure, and (4) number of approvals measure.

A case study approach is adopted in part 2 to cross-validate the part ¹ research results. The Housing Authority and a private¹ developer's organisation are chosen for comparison. The documents prescribing the rules, procedures and organizational structure of the projects are collected from the Housing Authority and the Private Developer. In this study, the tender section of the "Master Process Manual" from Housing Authority and the "Procedural Guideline for Tendering Process" from the Private Developer are referred. Based on the information given in those two documents, a comparison of their bureaucratic features is made on the numbers of (1) rules and procedures to follow during the tender process, (2) mandatory approvals required, (3) levels of record keeping delineated in the project procedural documents, (4) hierarchies in the organizational chart, (5) specialization of roles. (See Bozeman and Rainey 1998; Rainey et al 1995).

In addition, the project management system of each organization is classified into three subsystems according to Walker's (2002) suggested classification: managing sub-system, control sub-system, and operating sub-system. The number of roles assigned to the project participants in the three sub-systems are compared to indicate whether a particular sub-system in an organization is susceptible to / overwhelmed with a large number of roles.

¹ The private developer is a major real estate listed company in Hong Kong. Authors have to seek consent before disclosure of the developer's identity.

RESULTS

Part 1

A total of 213 questionnaire are sent to the construction managers and architects and the valid number of return is 72.

The mean scores of the five bureaucratic features and red tape features in the Housing Authority and the private developers are shown in Table 1.

Table 1 Degree of bureaucracy and red tape (t-test)

	Housing Authority	Private Developers	Paired difference	S.D.	T	Sig.
Hierarchies	4.9306	3.5694	1.3612	1.54579	7.472	0.000
Rules and procedures	5.6111	4.0694	1.5417	1.40171	9.333	0.000
Approvals	4.7500	3.5972	1.1528	1.37031	7.138	0.000
Record keeping	4.6389	3.4722	1.1667	1.65653	7.298	0.000
Specialization	4.7778	3.3889	1.3889	1.31680	8.950	0.000
Overall Bureaucracy	24.784	18.0971	6.6113	4.77670	11.744	0.000
Rules and regulations that:						
serve no purpose	3.9722	2.6250	1.3472	1.31256	8.709	0.000
ought to be cut	3.5139	2.3333	1.1806	1.35653	7.385	0.000
may allow discretionary enforcement	3.4444	2.1528	1.2916	1.26087	8.692	0.000
cause serious consequences in non-compliance	3.5417	4.6528	-1.1111	1.81198	-5.203	0.000
must be followed despite their ineffectiveness	3.6944	2.5694	1.1250	1.40749	6.7824	0.000
Overall red tape	18.1666	14.3333	3.8333	3.24146	10.035	0.000

Note: df=71; comparison was conducted at 95% significance level

The results show that the Housing Authority has higher scores in all five bureaucratic features and is, overall, more bureaucratic than the private project organizations. With regard to the five questions measuring the degree of red tape, the overall red tape score for Housing Authority is higher than the private project

organizations. Hence, both hypotheses are tested and supported. Only one question addressing red tape is rated higher in the private project organizations. That question is "Whether the client takes the non-compliance of rules and procedures very seriously". The result shows that the compliance of rules and procedures is

more important in private organisations than in the public Housing Authority – consequence of non-compliance is taken much more seriously in the private sector.

The correlation analysis of the bureaucratic features in the Housing Authority and private project organizations are shown in Table 2.

Table 2 Correlation analysis of the bureaucratic features

	Hierarchies	Rules and procedures	Approvals	Record keeping	Specialization
Private Developers	Housing Authority (shaded figures)				
Hierarchies	1	.364**	.431**	.410**	.399**
Rules and procedures	.539**	1	.334**	.036	.034
Approvals	.443**	.532**	1	.052	.050
Record keeping	.296*	.0345	.029	1	.515**
Specialization	.347**	.0546	.041	.279*	1

Note: ** correlation is significant at 0.01 level (2-tailed); * correlation is significant at 0.05 level (2-tailed); N=72

The following three characteristics are inferred from Table 2:

- The more rules there are in governing the operations of tasks, the more approvals are required in the task processes.
- The more specialised the task is, the more records are required to be kept.
- The amount of rules and procedures, approvals, record keeping and specialization increase with the additional number of hierarchies in the organisation structure.

It is also found that rules and procedures is significantly and, positively, correlated with red tape. As Bozeman (2000) proposes that “red tape is one of the bureaupathologies”, the existence of red tape affects the efficiency of an organization as resources are wasted to comply with these rules and procedures. According to Bozeman (2000), rules and procedures are essential elements to govern the operation of an organization; however, if there are excessive rules and procedures which do not serve any functional purpose, they become red tape.

Part 2

From the tender section of “Master Process Manual” of the Housing Authority and the “Project Procedural Guideline for Tender Process” of the Private Developer, a comparison is made of the degree of bureaucracy in terms of the five features (see Table 3), namely, hierarchies, rules and procedures, record keeping, approvals and specialised roles (i.e., number of parties). The number of hierarchies are counted from the organisation charts (see fig. 1 for Housing Authority’s organisation chart). The rules and procedures involved in the tendering process are represented by code numbers in fig. 2 (and is to be read in conjunction with Appendix I), for instance, 5.1.1 represents preparation of tender drawings. Fig.2 also shows an example of identification of when the records and approvals are required in the tender process. An example of the analysis is given in Appendix I.

The number of parties involved in the three project systems (managing system, control system, operating system) are also counted and shown in Table 3.

Table 3 Comparison of the Housing Authority and a Private Developer

	Housing Authority	Private Developer
Bureaucratic features		
Hierarchies	8	5
Rules and Procedures	65	40
Approvals	9	7
Records keeping	7	1
Specialization of roles (no. of parties)	123	58
No. of parties in:–		
Managing System	12	12
Control System	8	2
Operating System	50	29

Fig.1 Organization Chart of Housing Authority Projects

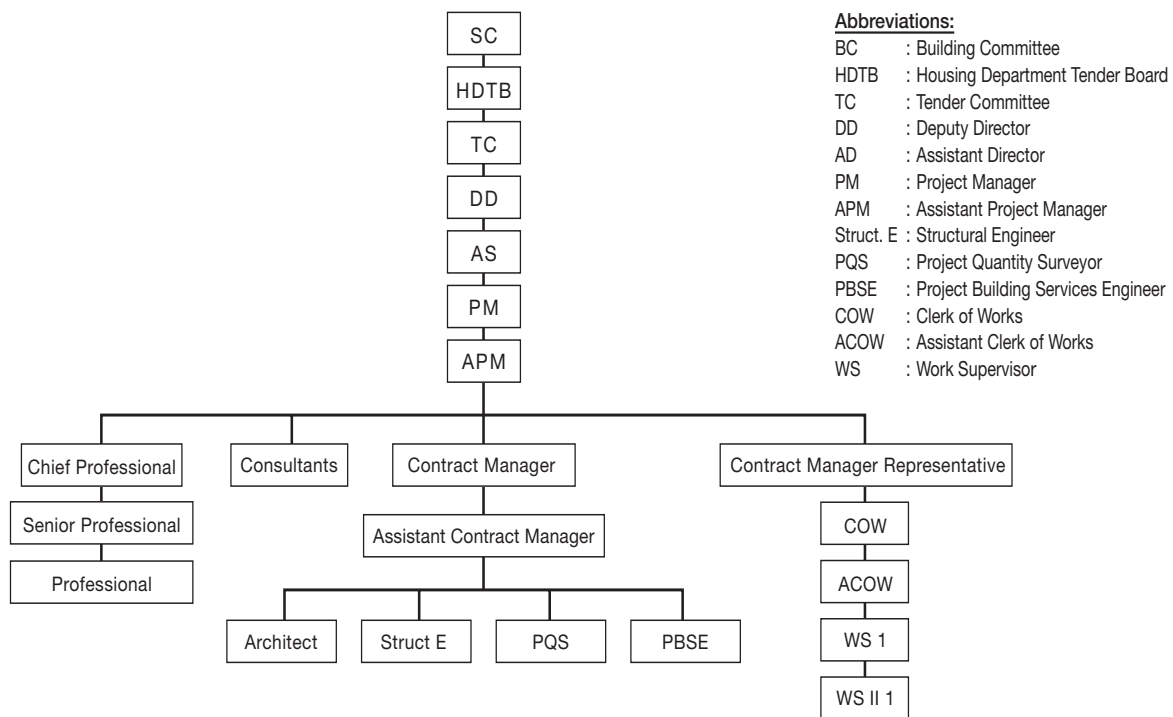
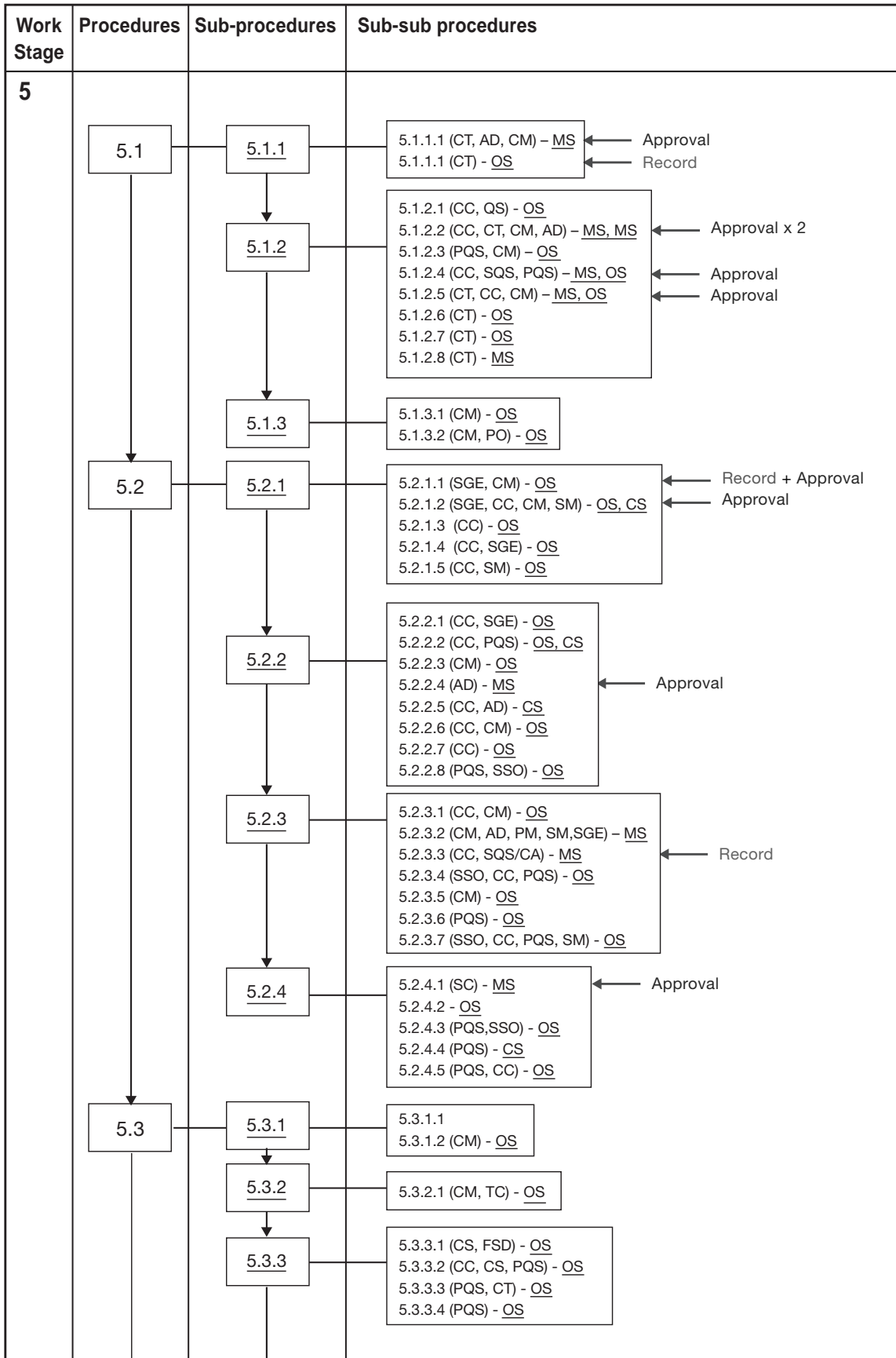

Fig.2 Extract from the Housing Authority’s Master Process Manual

Legend: MS (managing system); CS (control system); OS (operating system); CT (contract team); AD (Assistant Director); CM (contract manager): CC(contract coordinator): QS (quantity surveyor): PQS (project quantity surveyor); SQS (Senior quantity surveyor); SGE (Senior geotechnical engineer); SM (Senior manager); SSO (Senior survey officer); CA (Chief Architect); TC (Tender Committee); CS (Committee’s secretary); FSD (Finance Senior Director).

Housing Authority Tender Procedural Guide



The degree of each bureaucratic feature identified from the Housing Authority project organization is higher than that in the Private Developer's project organization. The result from the part 1 questionnaire is validated. The hypothesis that "public project organization has a higher degree of bureaucracy than in private project organization" is not rejected.

By comparing the frequencies of the roles in the three systems (managing system, control system, operating system) in the two organizations, it is found that the Housing Authority has set up more rules and procedure in both the control and operating systems. That shows that the Housing Authority has a greater demand on role delineation / specialization in the organization. It can be inferred that the existence of red tape is due to the Housing Authority's over emphasis on the control and operating systems.

CONCLUSION

In this research, it is found that the Housing Authority project organization has a higher degree of bureaucracy and red tape than the private project organization. In addition, results show that there are some correlations among bureaucratic features and between bureaucracy and red tape.

As proposed by Boyne (2002), a certain degree of bureaucracy is necessary for public organizations to safeguard their operations and ensure their accountability. The public organizations are publicly funded and should be under public scrutiny. As a result, it is necessary for public organizations to be more bureaucratic. Although the rigid and formal bureaucratized organizational structure is ill-suited to deal with the change of environment, Mullins (1996) notes that only those organizations subjected to a turbulent environment need to be flexible in order to adapt to environmental changes. Within a turbulent environment like Hong Kong which has a highly speculative real estate market, the private project organizations need to be more organic in order to cope with the rapid environmental

changes. Therefore, the private project organizations generally have a lower degree of bureaucracy. When comparing with private project organizations, the public (housing) project organizations are subjected to less dynamic environment, as their developments are less influenced by the economic factors, thus they may maintain their highly bureaucratized structures to achieve maximum efficiency in attaining their social and political goals.

ACKNOWLEDGEMENT

This paper is abstracted from a dissertation, written by LAM Bing Chuen, which was granted the HKIS Dissertation Award from the QS Division. Full paper version is found in the International Journal of Construction Management.

REFERENCES

- Allison, G (1979). Public and private management: are they fundamentally alike in all unimportant respects? In Shafritz, J. and Hyde, A (Eds), *Classics of Public Administration*. Belmont: Wadsworth, 1992.
- Antonsen, M, Jorgensen, T (1997). The publicness of public organizations. *Public Administration*, 75.
- Beetham, D (1987) *Bureaucracy*. 1st ed. Keynes: Open University Press.
- Boyne, GA (2002). Public and private management: What's the difference. *Journal of Management Studies* 39(1)
- Bozeman B (2000) *Bureaucracy and Red Tape*. 1st ed. New Jersey, Prentice-Hall, Inc.
- Bozeman, B (1987). *All Organizations are public*. London: Jossey-Bass
- Bozeman, B (1993). *A Theory of Government Red*

Tape *Journal of Public Administration Research and Theory* 3(3)

Bozeman, B, Rainey, H, (1998). Organizational Rules and the Bureaucratic Personality. *American Journal of Political Science* 42(1)

Bozeman, B, Reed, P, Scott, P (1992). Red Tape and task delays in public and private organizations. *Administration and Society*, 24(3)

Bozeman, B, Scott, P (1996). Bureaucratic Red Tape and Formalization: Untangling Conceptual Knots. *American Review of Public Administration* 26(1)

Cherns AB, Bryant DT (1984), Studying the client's role in construction management. *Construction Management and Economics*. 2, pp 177-84 .

Crozier M (1964). *The bureaucratic phenomenon*. 2nd ed. Chicago: The University of Chicago Press.

Dahl, R, Lindblom, C (1953). *Politics, Economics and Welfare*. Chicago: University of Chicago Press.

Fottler, M (1981). Is management really generic? *Academy of Management Review* 6.

Liu AMM, Walker A (1998), Evaluation of Project Outcomes. *Construction Management and Economics*. 16, 2, 209-219

Merton RK (1940). Bureaucratic structure and personality. In: Merton RK et al. *Readers in Bureaucracy*. New York: The free press, 361-371

Metcalf, L (1993). Public management: from imitation to innovation. In Kooiman, J (Ed.), *Modern Governance*. London: Sage.

Mouzelis, NP (1975). *Organization and bureaucracy*. 1st ed. London, Redwood Burn Limited Trowbridge and Esher.

Mullins, LJ (1996). *Management and organizational behaviour*. 4th ed. Portsmouth: Pitman publishing

Newcombe R (1994), Procurement Paths – a power paradigm. *Proceedings of CIB W92 – Procurement Systems, East Meets West*. Rowlinson S (ed.), University of Hong Kong, Dec. pp 243-250

Newman, W, Wallender, H (1978). Managing not-for-profit enterprises. *Academy of Management Review* (3)

Niskanen, W (1971). *Bureaucracy and Representative Government*. Chicago: Aldin-Atherton

Rainey H (1989). Public management: recent research on the political context and managerial roles, structures and behaviour. *Journal of Management*, 15

Rainey, H, Pandey, S , Bozeman, B (1995). Public and Private Managers' Perceptions of Red Tape. *Public Administration Review* 15

Ring, P, Perry, J (1985). Strategic management in public and private organizations: implications of distinction contexts and constraints. *Academy of Management*

Sanders S, RL (1997). The future of bureaucracy. *Information Management Journal*, 31(1), 44

Scott, PG, Pandey, SK (2000). The influence of Red Tape on Bureaucratic Behaviour: An Experimental Simulation. *Journal of Policy Analysis and Management* 19(4)

Stewart, J, Ranson, S (1988). Management in the public domain. *Public Money and Management*. 8(2)

Thompson, VP (1961). *Modern organization*. 1st ed. Canada: Alfred A. Knoff, Inc

Walker A (2002), *Project Management in Construction*. Oxford: Blackwell Science.

Walmsley, G, Zald, M (1973). *The Political Economy of Public Organizations*. Lexington, MA: Lexington Books

Weber, M. (1947). *The theory of social and economic organization* 1st ed. London: Edinburgh.

APPENDIX I

Example of analysis of Housing

Authority's project organisation

Housing Authority project's tender stage

(legend: MS=managing system; OS=operating system)

5 Tender Stage

5.1 Prepare tender documents

5.1.1 Preparation of Tender Drawing

5.1.1.1 If some works cannot be detailed or drawings cannot be completed for billing, Contract Team decides on the drawing issue program to be specified in the contract and seeks agreement from respective Assistant Director and the Contract Manager. **(MS: Directing, approving)**

5.1.1.2 Contract Team prepares copy negative of all as-measured drawings, if any, and keeps these unchanged for contract and record purposes **(record keeping) (OS: Operating)**

5.1.2 Preparation of other tender documents

5.1.2.1 Contract Coordinator completes Project Design information sheet, advises in selection and compilation of appropriate standard BQs and agrees with Quantity Surveyor on items within standard BQs which are to be measured separately or as variations to the standard block. **(OS: operating, advising, co-operating)**

5.1.2.2 Contract Coordinator finalizes with Contract Team the nature and value of any Prime Cost Sums and / or Provisional Sums to be included in the contract, and identifies the attendance associated with these items, for inclusion in the Project Specification. Agreement is to be sought from Contract Manager **(MS: Approving)**. Where

Provisional Items and Provisional Sums are required to be included in the tender, Contract Manager should seek the endorsement of Assistant Director on the extent / scope and amount to be inserted prior to tender. **(MS: Approving)**

5.1.2.3 Project Quantity Surveyor provides Contract Manager with updated estimate of contract for completing contract particulars. **(OS: operating)**

5.1.2.4 Contract Coordinator forwards information for compilation of contract particulars and calculation of liquidated damages to Senior Quantity Surveyor for approval **(MS: Approving)** and passes the completed contract particulars and assessed liquidated damages to Project Quantity Surveyor for incorporation in the tender documents. **(OS: operating)**

5.1.2.5 Contract Team prepares List of Elements of Works of Safety concern. Contract Coordinator obtains Contract Manager's endorsement to the List **(MS: Approving)**. Contract Team prepares tender document with reference to guideline for preparation of Project Specific Specification for Elements of Works of Safety Concern **(OS: operating)**

5.1.2.6 Contract Team takes action and follows the procedures in accordance with the implementation of the Pay for Safety Scheme. **(OS: operating)**

5.1.2.7 Contract Team prepares List of Elements requiring Warranties to be included in the Contract. **(OS: operating)**

5.1.2.8 Contract Team checks that the provision has been made to allow for the testing of materials and workmanship. **(MS: monitoring)**

Quality Assessment Of Kinematic Airborne Laser Survey

Omar Al-Bayari¹, Bassam Saleh² and Maurizio Barbarella³

ABSTRACT

Kinematic positioning is considered as the most important factor in creating a reliable digital terrain model (DTM), by airborne laser scanning. It requires as well, an accurate and consistent base-to-aircraft vector throughout the survey. Different experiments were carried out in Italy and Portugal in collaboration with Auselda ADE group using the TopEye airborne laser scanner. Three main problems encountered in kinematic airborne laser surveys were studied: (1) the radio frequency interference (RFI) with the global positioning system (GPS) signal, (2) the use of more than one reference station when long trajectory surveys are needed and their effects on the GPS results, and finally, (3) the effect of the distance between the reference station and the rover receiver on the GPS solution and consequently on the DTM. Geogenuis and TopEye softwares were used for processing the GPS and laser data. Some recommendations were proposed by the authors to be implemented on the helicopter to improve the reception of the GPS signal, and they proposed as well a limitation for the distance between the reference station and the rover receiver.

KEYWORDS

airborne laser scanning, GPS, DTM, interference, antenna, accuracy

INTRODUCTION

The airborne laser scanning technique is considered as one of the most reliable techniques for DTM generation [Ackermann (1999)]. This technique is based on the collection and determination of the xyz coordinates of a large number of points on the topographic scanned

surface. The cloud of collected points is modeled using different algorithms [Vosselman and Dijkman (2001), Axelsson (1999)]. This technique is used for DTM generation [Ackermann (1999); Axelsson (2000); Al-Bayari et al. (2002)], building extraction [Vosselman and Dijkman (2001)], and for many other applications based on the height determination such as trees height detection [Haala and Brenner (1999)]. The airborne laser scanners enable the acquisition of elevation data with an accuracy of 0.1 m [Casella (1999)]. This accuracy depends on many factors [Huising and Gomes Pereira (1998)], such as the quality of calibration of the group of sensors of the laser scanner [Skaloud and Vallet (2002); Mostafa and Hutton (2003)], the quality of data processing [Ackermann (1999); Axelsson (1999)], topography and vegetation [Kraus and Pfeifer (1998)].

¹ Assistant Professor, Department of Surveying and Geomatics Engineering, Faculty of Engineering, Al-Balqa' Applied University, Al-Salt 19117, Jordan, E-mail: obayari@bau.edu.jo

² Associate Professor, Department of Surveying and Geomatics Engineering, Faculty of Engineering, Al-Balqa' Applied University, Al-Salt 19117, Jordan, E-mail: bsaleh@wanadoo.jo

³ Professor, DISTART, University of Bologna, Faculty of Engineering, Viale Risorgimento, 2, Bologna 40136, Italy, E-mail: Maurizio.Barbarella@mail.ing.unibo.it

A series of experiments were carried out in Italy and Portugal in collaboration with Auselda ADE group, using the TopEye airborne laser scanner system with the following objectives:

- 1 To find the system accuracy.
- 2 To define and overcome the problems encountered in kinematic airborne laser survey (Al-Bayari et al. 2002) to create a reliable DTM.
- 3 To find the RFI effects on the GPS signal, in order to improve the reception of the GPS signal.
- 4 And finally, to find the effects on the GPS results when using more than one reference station in case of long trajectories.

DESCRIPTION OF THE AIRBORNE LASER SCANNING SYSTEM

The TopEye system [Axelsson (2000)] is an airborne laser system, which consists of two sensor groups. The first sensor group is a laser range finder, which is used to measure the distance from the laser range finder to the terrain surface. The second sensor group consists of GPS and INS which determine the absolute position and the orientation of the laser range finder at the time of measurement. The system scans the ground across the track of the Helicopter and measures the distance by emitting up to 7000 laser pulses per second. The TopEye system could

record four returns for each laser pulse (Fig. 1). The records of different returns within a single laser pulse help to identify the height of the objects on the terrain, such as trees, buildings, power lines, etc. [Al-Bayari et al. (2001)]. At the Bracigliano and Sarno landslides in Italy, the system was set up to record the first and the last returns in order to determine the ground DTM and the vegetation height.

DESCRIPTION OF THE EXPERIMENTS

The first experiment was undertaken at the Bracigliano and Sarno landslides in the south of Italy, where we captured 7 strips at the first landslide and 12 strips at the second one (see Fig. 2). The second experiment was carried out along the Trieste highway in northern Italy. Three receivers were used on board of the helicopter, a Trimble 4000ssi, Trimble 4700 and a Javad (Topcon), as well as, two reference stations at 17km from each other (Fig. 3). The third experiment was performed at the Trieste airport to check the calibration of the new internal Trimble antenna, installed inside the helicopter cabinet (Fig. 4). The fourth experiment was executed in Portugal. An airborne laser survey was carried out for an eighty kilometer (80 km) power line using three reference stations (Fig. 5).

Fig. 1 The TopEye system with four possible echoes

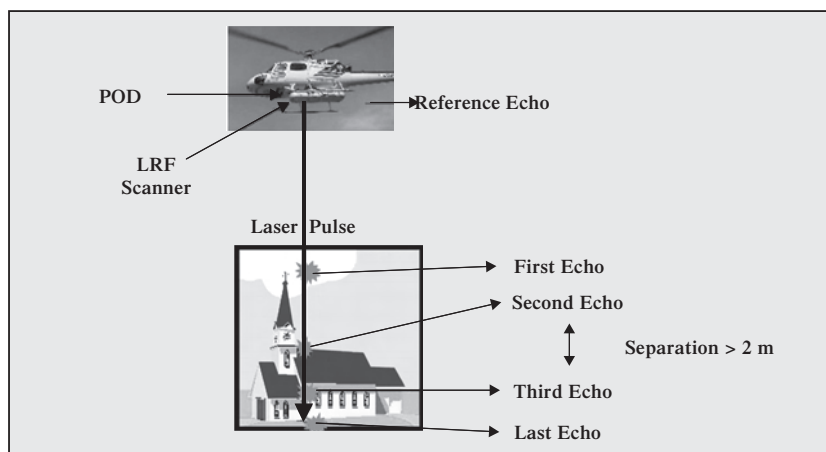
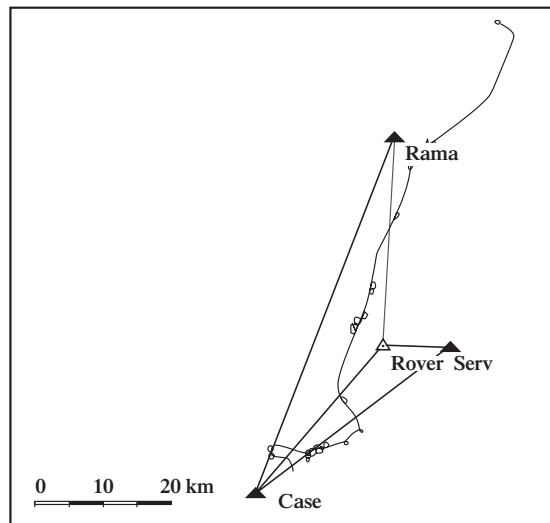

Fig. 5 Laser scanning trajectory for a power line survey in Portugal

EXPERIMENTAL RESULTS AND DISCUSSION

Influence of the antenna position on the GPS signal

Generally, GPS receivers filter the captured signals and amplify them by a low-noise amplifier. The most important noise of the system comes from this amplification. During the airborne laser survey with the external antenna, we noted that the Signal to Noise Ratio is less than that obtained with the normal antenna which is connected with the receiver on board. This may be due to the separation of the amplifier from the external antenna, which is installed on the tail of the Helicopter. Due to aeronautic regulations, it is forbidden to install large or heavy objects outside the helicopter. Therefore, the antenna is separated into two parts, the first part is installed on the tail of the helicopter and the second part which is the amplifier is installed inside the tail at one meter from the first part. We found that the use of an internal antenna (Fig.4) showed an improvement in the Signal / Noise ratio, especially in the zones where a loss of lock of the GPS signals was encountered due to interference problems (Fig. 6). These findings were verified at the Trieste Highway, and the Bracigliano and Sarno landslides experiments,

as a GPS solution (OTF) was obtained using the data captured by the internal antenna, and no solution was obtained for the data captured by the external antenna. Meanwhile, a DGPS solution was obtained using an external antenna. The TopEye software merges the GPS solution, INS data and laser data using a calibration file. The GPS offset vector from the frame system center of the helicopter body is written in the calibration file. For the use of another antenna, we need to introduce the new vector of the new internal antenna in the calibration file in order to obtain a good laser data. The calibration vector of the internal antenna could be found using a conventional instrument such as a total station or the laser data after processing with the external and internal antennas at the same time. We found that the internal antenna provides a better reception of the GPS signal compared with the external one. We observed as well, that the disturbance during the helicopter maneuver did not affect the final results and this can be verified by comparing the results from both antennas. Therefore, we used an external antenna if a loss of a GPS signal occurs over an area. The external antenna can be replaced easily by connecting the cable of the internal antenna directly on the receiver during the flight.

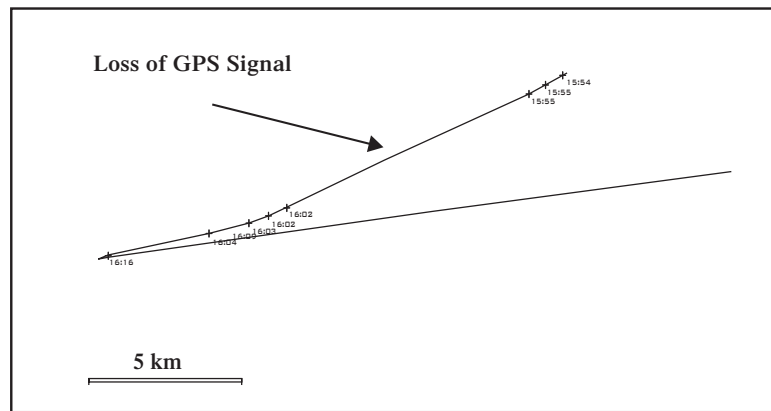
Fig. 6 Loss of GPS signals at the Trieste Highway

Signal Interference And GPS Receivers

Radio frequency interference with GPS signal was encountered in many parts of Italy (Fig. 6). This problem may be due to the illegal use of the radio frequencies in Italy. The RFI map of L1 signal, which was produced for navigation purposes could help in the location of the interference problem. Since the cost of the helicopter and laser scanning survey is high, a kinematic survey was carried out along Trieste Highway in order to verify the presence of in-band interference. This procedure gives an indication of the interference situation on the ground but not at the flight level. Three flights were carried out over the Trieste Highway and the same problem of interference was faced in a specific area for the same flight line. This enabled us to isolate the interference zone, but the same method could not, obviously, be applied at the Bracigliano or Sarno landslides. The interference problem has been identified either by loss of lock of L1 and L2 frequencies or just by loss of L2, and in some cases by receiving a low signal / noise ratio (SNR). The use of the most recent generation of receivers, such as JAVAD (Topcon), and Trimble 4700, in these experiments improved the SNR. The quality of kinematic GPS survey will be much better if the SNR is high because the noise will be low in the observations. These receivers demonstrate good capacity to receive the signal in hard conditions [Vorobiev et al. (1998)]. Furthermore, new algorithms are

used in these receivers to resolve the in-band interference and jamming signals. All receivers on board have received a good signal / ratio during the first experiment, as compared to the Trimble 4000ssi receiver, which was used by the TopEye system and connected to the external antenna. Consequently we have suggested the installation of a geodetic antenna inside the helicopter cabinet (see Fig. 4) and the use of the new generation of GPS receivers. The company took in consideration these suggestions and adopted the Trimble 4700 receiver on board of the helicopter.

The GPS Solution For A Long Trajectory

During the laser airborne survey of a power line in Portugal, three reference stations were used (Fig. 5). GeoGenius software was used to obtain the OTF solution for the whole helicopter trajectory. The three reference stations were used in the processing of the entire survey session. Normally the OTF solution obtained by the software is not reliable over a long distance, considering the ionospheric problem over a distance greater than 20 km [Cannon et al. (1996)]. The TopEye software merges the GPS data with laser and INS data to calculate the coordinates of laser returns. The file which contains the best GPS solution is elaborated by taking into consideration the nearest reference station. Therefore, the best

solution was obtained using CASC station (from the beginning of the survey at 11:20 AM until 12:00 noon), SERV station (from 12:00 noon till 12:38) (see Fig. 7), and using finally RAMA station (from 12:38 until the end of the survey 13:02) (see Fig. 8). This solution was used in the final GPS file for processing the laser data.

Since the ambiguity resolution is influenced by the ionosphere, the distance between the reference station and the helicopter should be taken into consideration and should not exceed 20 km. This result was also confirmed,

on the Portugal experiment (see Fig. 9). Finally, the use of two reference stations with 17 km apart from each other in the Trieste Highway experiment did not show any discrepancy in the kinematic results (see Fig. 10). The use of two reference stations can also confirm the reliability of the airborne GPS data. Recently, new technologies in the GPS data processing softwares appeared such as Bernese 5 (Hugentobler et al. 2005). The elaboration of kinematic GPS data could be done from two reference stations. This software was not available during the survey. Moreover, TopEye is still using Geogenius software for its simplicity.

Fig. 7 Difference in height calculated from the two obtained GPS solutions with respect to stations CASC and SERV

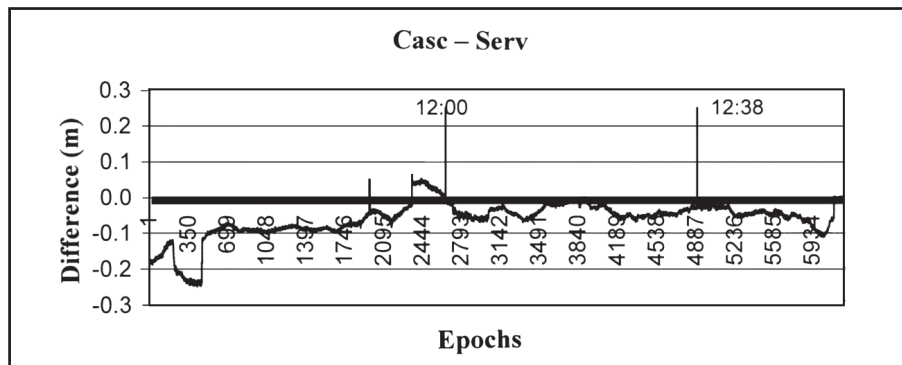

Fig. 8 Difference in height calculated from the two obtained GPS solutions with respect to stations SERV and RAMA

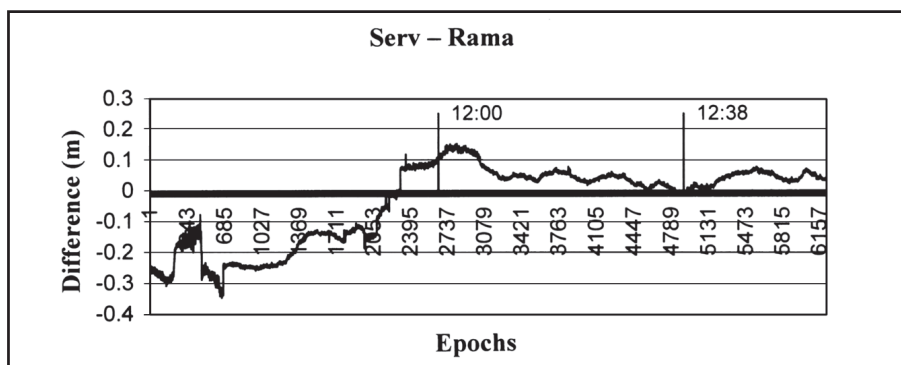

Fig. 9 Difference in height calculated from the two obtained GPS solutions with respect to stations CASC and RAMA separated by 50 km

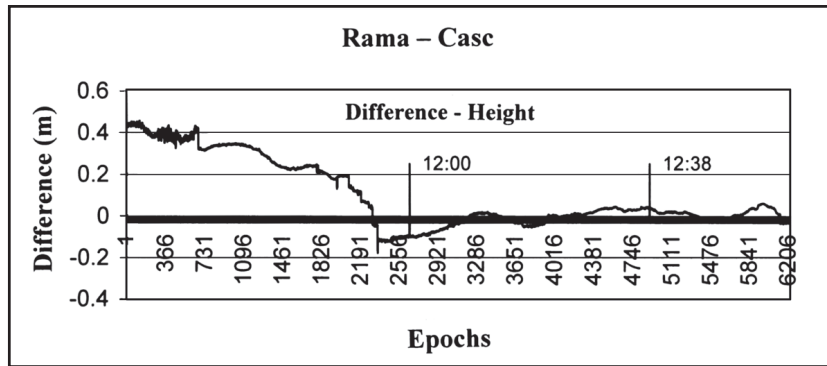
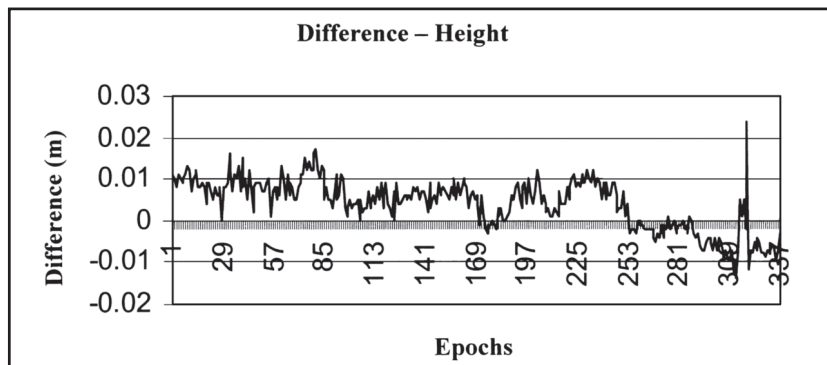

Fig. 10 Difference in height calculated from the two obtained GPS solutions with respect to two reference stations separated by 17 km at the Trieste Highway



Accuracy of the obtained DTM

The DTM resulting from an airborne laser survey could be obtained by OTF or smoothed DGPS. GeoGenius software was used to obtain the DTM at Bracigliano landslide using these methods. A

kinematic GPS survey was carried out for a specific part of the Bracigliano landslide. Fig. 11 shows the variation in height between this survey and the DTM obtained by OTF.

Fig. 11 Difference in height between kinematic GPS survey and DTM created by laser survey using the OTF solution

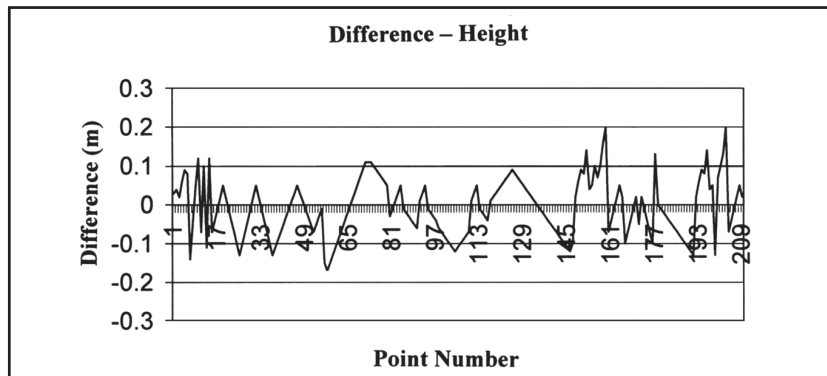

The accuracy of a DTM depends on many factors, such as the quality of GPS solution, synchronization of INS and GPS sensors [Skaloud and Vallet (2002)], flight height [Kilian (1994); Hofton et al. (2000)], angle of scanning, topography and vegetation [Kraus and Pfeifer (1998)]. The DTM could be obtained by OTF or smoothed DGPS solutions. The accuracy is estimated at 0.1 m for OTF solution and 2.5m for DGPS using GeoGenius software. Table 1 gives the difference in height between rapid static GPS and airborne laser scanning measurements obtained with a flying height of 195 m over a flat terrain. The effect of flight height on the DTM was found by comparing the results of two strips over a flat terrain at two different heights 195m and 750m. This effect is found to be around 0.1 m.

The standard error is estimated at 0.03 m and 0.08 m for the heights 195 m and 750m respectively. The error variation is due to the variation of laser foot print diameter and number of laser points/m² at different heights. The effect of topography and vegetation have been tested on different types of terrain: (1) a flat terrain without vegetation, (2) a steep terrain without vegetation with a slope ranging from 20 to 45 degrees, and finally, (3) a steep terrain of the same slope, covered by vegetation. Table 2 gives the results obtained by the airborne laser system and rapid static GPS technique over the three types of terrain. The effect is found to be 0.11, 0.18, and 0.33 m for the first, second and third type of terrain respectively.

Table 1 *Difference in height between the rapid static GPS and the airborne laser scanning measurements obtained with a flying height of 195 m and 750m over a flat terrain*

Point No.	Coordinates Obtained by Rapid Static GPS Technique			Coordinates Obtained by the Airborne Laser Scanner at 195m			Difference in Height (m)	
	Northing	Easting	Height	Northing	Easting	Height	195m	750m
1	4922247.406	498824.960	102.776	4922247.29	498825.00	102.76	0.02	0.09
				4922247.30	498824.82	102.81	-0.03	0.05
				4922247.43	498824.80	102.80	-0.02	0.10
2	4922214.584	498782.637	103.702	4922214.63	498782.86	103.74	-0.04	-0.04
				4922214.43	498782.86	103.73	-0.03	-0.06
				4922214.52	498782.19	103.73	-0.03	-0.09

Table 2 *Difference in height between the rapid static GPS and airborne laser scanning measurements due to different types of terrain*

Terrain Type No.	Terrain Type	Difference in Height Between GPS and Laser Measurements for Three Points (m)			Standard Error (m)
1	Flat	0.130	0.060	0.048	0.106
2	Steep without Vegetation	0.115	0.110	0.198	0.180
3	Steep with Vegetation	0.216	0.375	0.175	0.330

CONCLUSIONS

Through out this study, the following points are concluded:

- 1 The accuracy of airborne laser scanning depends on many factors such as the GPS solution, flying height, topography and vegetation as demonstrated in our experiments. The accuracy of a DTM obtained by an airborne laser scanner could reach 0.1 m. This accuracy of 0.1 m is acceptable for many engineering projects and applications.
- 2 The Radio Frequency Interference problem could be decreased by using the last generation of GPS receivers, which have an efficient interference / jamming suppression system integrated into the GPS chip. The Trimble 4000ssi receiver was replaced by the Trimble 4700 after these experiments and the performance of the TopEye system was improved.
- 3 The installation of an internal Geodetic antenna inside the helicopter improved the reception of the GPS signal, especially when an interference problem with the GPS signal is encountered. The internal antenna is used now inside the helicopter cabinet after the validation of these experiments.
- 4 The usage of more than one reference station in processing the data is recommended for any survey mission, the distance between the rover and reference station should not exceed 20 km. The use of new softwares such as Bernese 5 helps much in processing the data from two stations simultaneously.

ACKNOWLEDGEMENTS

The authors gratefully acknowledge C Zippilli for his support during this work. The authors would like to acknowledge RT3 group (Auselda AED and Elifriulia) for their help and cooperation in the execution of the experiments

with the TopEye laser airborne system and providing the laser data. The authors also thank GeoTop-Italy for providing Javad GPS receiver (Topcon) for this work.

REFERENCES

Ackermann F (1999), Airborne Laser Scanning – Present Status and Future Expectations, *Journal of Photogrammetry & Remote Sensing*, vol. 54, 64-67.

Al-Bayari O, Al-Hanbali N, Barbarella M, and Nashwan A (2002), Quality Assessment of DTM and Orthophoto Generated by Airborne Laser Scanning System Using Automated Digital Photogrammetry, *ISPRS, PCV'02 Proc. IAPRS*, vol. XXXIV, part 3A/B, ISSN 1682-1750.

Al-Bayari O, Barbarella M, Dubbini M, Fazio C, and Turturici L (2001), Valutazione dei risultati di un rilievo laser scanning su un'area a rischio idro geologico, *Bollettino della SIFET* (2), 19-27.

Axelsson P (1999), Processing of Laser Scanner Data – Algorithms and Applications, *ISPRS Journal of Photogrammetry & Remote Sensing*, vol. 54, 138-147.

Axelsson P (2000), DEM Generation From Laser Scanner Data Using Adaptive TIN Models, *International Archives of Photogrammetry and Remote Sensing*, Vol. XXXIII, Part B4, 11-118, Amsterdam.

Baltsavias EP (1999), Airborne Laser Scanning: Existing Systems and Firms and Other Resources, *ISPRS Journal of Photogrammetry and Remote Sensing*, 54:2, 164-198.

Cannon ME, and Sun H (1996), Experimental Assessment of a Non-dedicated GPS Receiver System for Airborne Altitude Determination, *ISPRS Journal of Photogrammetry & Remote Sensing*, 51, 99-108.

Casella V (1999), Le Potenzialità del Laser Scanning per la Conoscenza del Territorio, Bollettino della SIFET, 1:2, 87-96.

Haala N and Brenner C (1999), Extraction of Building and Trees in Urban Environments, ISPRS Journal of Photogrammetry & Remote Sensing, vol. 54, 130-137.

Hofton MA, Blair JB, Minster JB, Ridgway JR, Williams NP, Bufton JL, and Rabine DL (2000), An Airborne Scanning Laser Altimetry Survey of Long Valley, California, International Journal of Remote Sensing, 21:12, 2413-2437.

Hugentobler U, Dach R, and Fridez P (2005), Bernese GPS Software Version 5.0 Documentation, Astronomical Institute, University of Berne, Bern, Switzerland, 127-132.

Huising EJ, and Gomes Pereira LM (1998), Errors and Accuracy Estimates of Laser Data Acquired by Various Laser Scanning Systems for Topographic Applications, ISPRS Journal of Photogrammetry & Remote Sensing, 53:5, 245-261.

Kilian J (1994), Calibration Methods for Airborne Laser System, Journal of Photogrammetry & Remote Sensing, 30:1, 42-46.

Kraus K, Pfeifer N (1998), Determination of Terrain Models in Wooded Areas with Airborne Laser Scanner Data, ISPRS Journal of Photogrammetry & Remote Sensing, 53:4, 193-203.

Mostafa M, and Hutton J (2003), Emerge DSS: A Fully Integrated Digital System for Airborne Mapping Mostafa - calibration, ISPRS International Workshop on Theory, Technology and Realities of Inertial / GPS Sensor Orientation, Commission 1, WGI/5, Castelldefels, Spain, 22-23 September.

Reid B, Sccherzinger B, and Lithopoulos E (1996), The Position and Orientation System

(POS) for Airborne Survey Applications, The second International Airborne Remote Sensing Conference and Exhibition, part B3, 467-471, San Francisco, California.

Skaloud J, and Vallet J (2002), High Accuracy Handheld Mapping System for Fast Helicopter Deployment, International Symposium on Geospatial Theory, ISPRS Comm IV. Ottawa, Canada, 9-12th July.

<http://www.isprs.org/commission4/proceedings/pdfpapers/381.pdf>

Vorobiev M, Prasolov V, Zhdanov A, and Ashjaee J (1998), In-band Interference Suppression for GPS/GLONASS, Proc. ION GPS-98, 769-774.

Vosselman G, and Dijkman S (2001), 3D Building Model Reconstruction from Point Clouds and Ground Plans, Proc. International Archives of Photogrammetry and Remote Sensing, vol. 34, part 3/W4, 37- 44, Annapolis, Maryland.